

To,
Deputy Director General of Forests (C),
Ministry of Environment, Forest and Climate Change,
Integrated Regional Office,
Bays no. 24-25,
Sector 31 A, Dakshin Marg,
Chandigarh – 160030
Email: ronz.chd-mef@nic.in

26.05.2026

Sub: Grant of Environmental Clearance (EC) to Industrial/Warehouse/Logistics Project located at Village- Firozpur, Tehsil & District- Palwal, Haryana: **Submission of Half Yearly Environmental Clearance compliance report for the period of October 2025 to March 2026.**

Ref: Environment clearance issued to Adani Logistics Limited by Ministry of Environment, Forest and Climate Change (Impact Assessment Division) vide letter dated 17/06/2022 bearing number - EC22A038HR110364.

Dear Sir,

Please refer to the above cited reference for the said subject matter. In connection with the same, it is to state that copy of the compliance report for Environmental Clearance for the period of **October 2025 to March 2026** is being submitted through soft copy (e-mail communication).

This is for your information and records please.

Yours faithfully,

For Adani Logistics Limited



Authorized Signatory

Adani Logistics Limited, Palwal, Haryana

Copy to: -

1. The Chairman, State Environment Impact Assessment Authority, Bay No. 55-58, Paryatan Bhawan, Sector – 2, Panchkula, Haryana
2. The Regional Officer, Haryana State Pollution Control Board, 3rd Floor, HSIIDC Office Complex, IMT Manesar, Gurgaon

Adani Logistics Ltd
Adani House, Plot No 83
Institutional Area, Sector 32
Gurugram 122001
NCR, India
CIN: U63090GJ2005PLC046419

Tel+91 124 255 5555
Fax +91 124 25555210
info@adani.com
www.adani.com

Status of the Conditions Stipulated in Environment Clearance

Half yearly Compliance report on Environment Clearance granted to "Industrial/Warehouse/Logistics Project located at Village- Firozpur, Tehsil & District- Palwal, Haryana" vide letter no. EC22A038HR110364 dated 17th June 2022.

S. No.	CONDITION	COMPLIANCE STATUS
Specific Conditions as recommended by MoEF&CC		
i	Abstraction of ground water shall be subject to the permission of Central Ground Water Authority (CGWA). Fresh water requirement shall not exceed 150 KLD during operational phase.	Presently the site is being developed in phased manner accordingly the permission for ground water extraction for 65 KLD has been granted vide NOC No. HWRA/INF/N/2025/790 dated 26.05.2025. The permission for remaining ground water will be taken once the site is fully operational. Details enclosed as Annexure XIII .
ii	As proposed, wastewater shall be treated in the onsite STP having a total 248 KLD capacity. At least 178 KLD of treated water from the STP shall be recycled and re-used for flushing (80 KLD), filter backwash (3 KLD) and for gardening (95 KLD during dry season). Excess treated water (about 76 KLD during monsoon season and about 28 KLD during winter season) shall be supplied to the nearby farmers for irrigation purposes. PP shall submit MoU for the disposal of excess treated water (outside the site) to the Regional Office of MoEF&CC along with six-monthly compliance report.	Presently the site is being developed in phased manner accordingly the generated sewage water is being treated in existing STP with a capacity of 55 KLD however the remaining capacity of STP will be developed in phased manner aligning with project development stages. Details enclosed as Annexure XI .
iii	The project proponents would commission a third-party study on the implementation of conditions related to quality and quantity of recycle and reuse of treated water, efficiency of treatment systems, quality of treated water being supplied for flushing (specially the bacterial counts), comparative bacteriological studies from toilet seats using recycled treated waters and fresh waters for flushing,	Noted for compliance

Status of the Conditions Stipulated in Environment Clearance

S. No.	CONDITION	COMPLIANCE STATUS
	and quality of water being supplied through spray faucets attached to toilet seats.	
iv	Area for greenery shall be provided as per the details provided in the project document, i.e., area under plantation/greenery will be 36,905.35 sq. m. The project being located in the National Capital Region (NCR) which is severely affected by poor air quality, the project proponent shall develop dense plantation at the project site using appropriate techniques in consultation with the forest department/horticulture department/ experts/ consultants etc., comprising of at least 3,071 nos. plants (including trees and shrubs) during the operation phase of the project as committed.	Presently the site is being developed in phased manner accordingly the green belt development is being done. Details enclosed as Annexure I .
v	The local bye-law provisions on rainwater harvesting should be followed. If local bye-law provision is not available, adequate provision for storage and recharge should be followed as per the Ministry of Urban Development Model Building Byelaws, 2016. As proposed, 10 RWH pits and stored in 2 Ponds of total 4,620 m ³ capacity shall be provided by PP for rainwater harvesting after filtration.	Presently the site is being developed in phased manner accordingly the rainwater harvesting structure are being developed as 27 nos. of recharge pits & 1 nos. of ponds. Details layout enclosed as Annexure II .
vi	The solid waste shall be duly segregated into biodegradable and nonbiodegradable components and handled in separate area earmarked for segregation of solid waste, as per SWM Rules, 2016. As committed, biodegradable waste shall be utilized through the OWC/Bio-Gas generation plant/bio-bin unit to be installed within the site. Inert waste shall be disposed of as per norms at authorized site. The recyclable waste shall be sold to authorized vendors/recyclers. Construction & Demolition (C&D) waste shall be segregated and managed as per C&D Waste Management Rules, 2016.	No canteen facility has been developed inside the premises. Domestic waste (in very small quantity) generated is being managed through local municipality.

Status of the Conditions Stipulated in Environment Clearance

S. No.	CONDITION	COMPLIANCE STATUS
vii	A detailed traffic management and traffic decongestion plan shall be drawn up to ensure that the current level of service of the roads within a 05 Kms radius of the project is maintained and improved upon after the implementation of the project. This plan should be based on cumulative impact of all development and increased habitation being carried out or proposed to be carried out by the project or other agencies in this 05 Kms radius of the site in different scenarios of space and time and the traffic management plan shall be duly validated and certified by the State Urban Development and the P.W.D./competent authority for road augmentation and shall also have their consent to the implementation of components of the plan which involve the participation of these departments.	Noted
viii	The PP shall provide electric charging points in parking areas for e-vehicles as committed.	Noted
ix	As committed, at least 10% of the electrical load shall be met through solar energy.	Noted Solar system is being developed in phase wise manner. Till date 250 kvA of solar energy already installed. Details enclosed as Annexure III .
x	The Environmental Clearance to the project is primarily under provisions of EIA Notification, 2006. The Project Proponent is under obligation to obtain approvals/ clearances under any other Acts/Regulations or Statutes as applicable to the project.	Noted and agreed.
Standard Conditions		
I	Statutory Compliance	
i	The project proponent shall obtain all necessary clearance/permission from all relevant agencies including town planning	Noted and complied. Approval letter from town

Status of the Conditions Stipulated in Environment Clearance

S. No.	CONDITION	COMPLIANCE STATUS
	authority before commencement of work. All the construction shall be done in accordance with the local building byelaws.	planning is enclosed as Annexure IV.
ii	The approval of the Competent Authority shall be obtained for structural safety of building due to earthquakes, adequacy of firefighting equipment etc. as per National Building code including protection measures from lightening etc.	Noted and complied. Structural Stability certificate enclosed as Annexure V.
iii	The project proponent shall obtain forest clearance under the provisions of Forest (Conservation) Act, 1980, in case of the diversion of forest land for non-forest purpose involved in the project.	Forest NOC Enclosed as annexure VI.
iv	The project proponent shall obtain clearance from the National Board for Wildlife, if applicable.	Not applicable.
v	The project proponent shall obtain Consent to Establish/Operate under the provisions of Air (Prevention & Control of Pollution) Act, 1981 and the Water (Prevention & Control of Pollution) Act, 1974 from the concerned State Pollution Control Board/Committee.	Consent to Establish obtained on 22.03.2024 vide letter No. HSPCB/Consent/: 313116324PALCTE56633400 & Consent to operate obtained on 01.01.2025 vide letter no. 313116325PALCTO82597692. Enclosed as annexure VII.
vi	The project proponent shall obtain the necessary permission for drawl of ground water/surface water required for the project from the competent authority.	The permission for ground water extraction for 65 KLD has been granted vide NOC No. HWRA/INF/N/2025/790 dated 26.05.2025. Details enclosed as Annexure XIII.
vii	A certificate of adequacy of available power from the agency supplying power to the project along with the load allowed for the project should be obtained.	Letter of power allotment from nearby Electrical Department is enclosed as Annexure VIII.
viii	All other statutory clearances such as the approvals for storage of diesel from Chief Controller of Explosives, Fire Department, Civil Aviation Department shall be obtained, as	Fire NOC enclosed as Annexure IX.

Status of the Conditions Stipulated in Environment Clearance

S. No.	CONDITION	COMPLIANCE STATUS
	applicable, by project proponents from the respective competent authorities.	
ix	The provisions for the solid Waste (Management) Rules, 2016, e-Waste (Management) Rules, 2016, and the Plastics Waste (Management) Rules, 2016 shall be followed.	Noted and complied
x	The project proponent shall follow the ECBC/ECBC-R prescribed by Bureau of Energy Efficiency, Ministry of Power Strictly.	Noted and agreed.
II	Air quality monitoring and preservation	
i.	Notification GSR 94(E) dated 25/1/2018 MoEF&CC regarding Mandatory implementation of Dust Mitigation Measures for Construction and Demolition Activities for project requiring Environmental Clearance shall be complied with.	Noted and agreed.
ii.	A management plan shall be drawn up and implemented to contain the current exceedance in ambient air quality at the site.	Being complied.
iii.	The project proponent shall install system to carryout Ambient Air Quality monitoring for common/ criterion parameters relevant to the main pollutants released (e.g. PM10 and PM2.5) covering upwind and downwind directions during the construction period.	Agreed
iv.	Diesel power generating sets proposed as source of backup power should be of the enclosed type and conform to rules made under the Environment (Protection) Act, 1986. The height of stack of DG sets should be equal to the height needed for the combined capacity of all proposed DG sets. Use of low Sulphur diesel. The location of the DG sets may be decided with in consultation with State Pollution Control Board.	Noted and agreed.

Status of the Conditions Stipulated in Environment Clearance

S. No.	CONDITION	COMPLIANCE STATUS
v.	Construction site shall be adequately barricaded before the construction begins. Dust, smoke & other air pollution prevention measures shall be provided for the building as well as the site. These measures shall include screens for the building under construction, continuous dust/ wind breaking walls all around the site (at least 3-meter height). Plastic/tarpaulin sheet covers shall be provided for vehicles bringing in sand, cement, Murram and other construction materials prone to causing dust polluting at the site as well as taking out debris from the site.	Noted and agreed.
vi.	Sand, Murram, loose soil, cement, stored on site shall be covered adequately so as to prevent dust pollution.	Noted.
vii.	Wet jet shall be provided for grinding and stone cutting.	Noted.
viii.	Unpaved surface and loose soil shall be adequately sprinkled with water to suppress dust.	Noted.
ix.	All construction and demolition debris shall be stored at the site (not dumped on the roads or open spaces outside) before they are properly disposed. All demolition and construction waste shall be managed as per the provisions of the Construction and Demolition Waste Rules, 2016.	Noted.
x.	The diesel generator sets to be used during 'Construction phase shall be low sulphur diesel type and shall conform to Environmental (Protection} prescribed for air and noise emission standards.	Noted and being complied.
xi.	The gaseous emission from DG set shall be dispersed through adequate stack height as per CPCB standards. Acoustic enclosure shall be provided to the DG sets to mitigate the noise pollution. Low sulphur diesel shall be used. The location of the DG set and exhaust pipe height shall be as per the provisions of the Central Pollution Control Board (CPCB) norms	Being complied.

Status of the Conditions Stipulated in Environment Clearance

S. No.	CONDITION	COMPLIANCE STATUS
xii.	For indoor air quality the ventilation provisions as per National Building Code of India.	Being complied.
III	Water quality monitoring and preservation	
i.	The natural drain system should be maintained for ensuring unrestricted flow of water. No construction shall be allowed to obstruct the natural drainage through the site, on wetland and water bodies. Check dams, bio-swales, landscape and other sustainable urban drainage systems (SUDS) are allowed for maintaining the drainage pattern and to harvest rainwater.	Noted and agreed.
ii.	Buildings shall be designed to follow the natural topography as much as possible. Minimum cutting and filling should be done.	Noted.
iii.	The quantity of freshwater usage, water recycling and rainwater harvesting shall be measured and recorded to monitor the water balance as projected by the project proponent. The record shall be submitted to the Regional Office, MoEF&CC along with six monthly Monitoring reports.	Noted. The online telemetry devices installed on site with data linkage to Haryana Water Resources Authority.
iv.	A certificate shall be obtained from the local body supplying water, specifying the total annual water availability with the local authority, the quantity of water already committed, the quantity of water allotted to the project under consideration and the balance water available. This should be specified separately for ground water and surface water sources, ensuring that there is no impact on other users.	The permission for ground water extraction for 65 KLD has been granted vide NOC No. HWRA/INF/N/2025/790 dated 26.05.2025. Details enclosed as Annexure XIII .
v.	At least 20% of the open spaces as required by the local building byelaws shall be pervious. Use of Grass pavers, paver blocks with at least 50% opening, landscape etc. would be considered as pervious surface.	Noted and complied.
vi.	Installation of dual pipe plumbing for supplying fresh water for drinking, cooking and bathing etc. and other for supply of	Noted and complied.

Status of the Conditions Stipulated in Environment Clearance

S. No.	CONDITION	COMPLIANCE STATUS
	recycled water for flushing, landscape irrigation, car washing, thermal cooling, conditioning etc. shall be done.	
vii.	Use of water saving devices/fixtures (Viz. low flow flushing systems; use of low flow faucets taps aerators etc.) for water conservation shall be incorporated in the building plan.	Noted and agreed.
viii.	Separation of grey and black water should be done by the use of dual plumbing system. In case of single stack system separate recirculation lines for flushing by giving dual plumbing system be done.	Noted and agreed.
ix.	Water demand during construction should be reduced by use of pre-mixed concrete, curing agents and other best practices referred.	Noted.
x.	Rain water harvesting recharge pits/ storage tanks shall be provided for ground water recharging as per the CGWB norms.	Presently the site is being developed in phased manner accordingly the rainwater harvesting structure are being developed as 27 nos. of recharge pits & 1 nos. of ponds. Details enclosed as Annexure II.
xi.	A rainwater harvesting plan needs to be designed where the recharge bores of minimum one recharge bore per 5,000 square meter of built up area and storage capacity of minimum one day of total fresh water requirement shall be provided. In areas where ground water recharge is not feasible the rainwater should be harvested and stored for reuse. The ground water shall not be withdrawn without approval from the Competent Authority.	Presently the site is being developed in phased manner accordingly the rainwater harvesting structure are being developed as 27 nos. of recharge pits & 1 nos. of ponds. Details enclosed as Annexure II.
xii.	All recharges should be limited to shallow aquifer.	Noted.
xiii.	No ground water shall be used during construction phase of the project.	Noted and complied.
xiv.	Any ground water dewatering should be properly managed and shall conform to the	Not applicable

Status of the Conditions Stipulated in Environment Clearance

S. No.	CONDITION	COMPLIANCE STATUS
	approvals and the guidelines of the CGWA in the matter. Formal approval shall be taken from the CGWA for any ground water abstraction or dewatering.	
xv.	The quantity of freshwater usage, water recycling and rainwater harvesting shall be measured and recorded to monitor the water balance as projected by the project proponent. The recorded shall be submitted to the Regional Office, MoEF&CC along with six monthly Monitoring report.	Noted. The online telemetry devices installed on site with data linkage to Haryana Water Resources Authority.
xvi.	Sewage shall be treated in the STP with tertiary treatment.	Noted and agreed.
xvii.	No sewage or untreated effluent water would be discharged through storm water drains.	Noted.
xviii.	Onsite sewage treatment of capacity of treating 100% wastewater to be installed. The installation of the Sewage Treatment Plant (STP) shall be certified by an independent expert and a report in this regard shall be submitted to the Ministry before the project is commissioned for operation. Treated wastewater shall be reused on site for landscape, flushing, cooling tower, and other end-uses. Excess treated water shall be discharged as per statutory norms notified by the Ministry of Environment, Forest and Climate Change. Natural treatment systems shall be promoted.	STP of 55 KLD has been installed and is in operation.
xix.	Periodical monitoring of the water quality of treated sewage shall be conducted. Necessary measures should be made to mitigate the odour problems from STP.	Noted.
xx.	Sludge from the onsite sewage treatment including septic tanks, shall be collected, conveyed and disposed of as per the Ministry of Urban Development, Control Public Health and Environmental Engineering Organization (CPHEEO) Manual on Sewerage and Sewage Treatment Systems. 2013.	Noted

Status of the Conditions Stipulated in Environment Clearance

S. No.	CONDITION	COMPLIANCE STATUS
IV	Noise monitoring and prevention	
i.	Ambient noise levels shall conform to residential area/commercial area/industrial area/silence zone both during day and night as per Noise Pollution (Control and Regulation) Rules, 2000. Incremental pollution loads on the ambient air and noise quality shall be closely monitored during construction phase. Adequate measures shall be made to reduce ambient air and noise level during construction phase so as to conform to the stipulated standards by CPCB/SPCB.	Noted.
ii.	Noise level survey shall be carried as per the prescribed guidelines and report in this regard shall be submitted to Regional Officer of the Ministry as a part of six-monthly compliance report.	Noted
iii.	Acoustic enclosures for DG sets, noise barriers for ground run bays, ear plugs for operating personnel shall be implemented as mitigation measures for noise impact due to ground sources.	Noted.
V	Energy Conservation measures	
i.	Compliance with the Energy Conservation Building Code (ECBC) of Bureau of Energy Efficiency shall be ensured, building in the State which have notified their own ECBC, shall comply with the State ECBC.	Noted and being complied.
ii.	Outdoor and common area lighting shall be LED.	Noted and being complied.
iii.	Concept of passive solar design that minimize energy consumption in buildings by using design elements, such as building orientation, landscaping, efficient building envelope, appropriate fenestration, increased day lighting design and thermal mass etc. shall be incorporated in the building design. Wall, window, and roof u-values shall be as per ECBC specifications	Noted Solar system is being developed in phase wise manner. Till date 250 kvA of solar energy already installed onsite. Details enclosed as Annexure III .

Status of the Conditions Stipulated in Environment Clearance

S. No.	CONDITION	COMPLIANCE STATUS
iv.	Energy Conservation measure like installation of CFLs/LED"s for the lighting the area outside the building should be integral part of the project design and should be in place before project commissioning	Noted.
v.	Solar, wind or other renewable energy shall be installed to meet electricity generation equivalent to 1 % of the demand load or as per the state level /local building bye-laws requirement, which is higher	Noted Solar system is being developed in phase wise manner. Till date 250 kvA of solar energy already installed. Details enclosed as Annexure III .
vi.	Solar power shall be used for lighting in the apartment to reduce the power load on grid. Separate electric meter shall be installed for solar power. Solar water heating shall be provided to meet 20% of the hot water demand of the commercial and institutional building or as per the requirement of the local building bye-laws, whichever is higher. Residential buildings are also recommended to meet its hot water demand from solar water heaters, as far as possible.	Noted Solar system is being developed in phase wise manner. Till date 250 kvA of solar energy already installed. Details enclosed as Annexure III .
VI	Waste Management	
i.	A certificate from the competent authority handling municipal solid wastes, indicating the existing civic capacities of handling and their adequacy to cater to the MSW generated from project shall be obtained.	Noted.
ii.	Disposal of muck during construction phase shall not create any adverse effect on the neighboring communities and be disposed taking the necessary precautions for general safety and health aspects of people, only in approved sites with the approval of competent authority.	Noted.
iii.	Separate wet and dry bins must be provided in each unit and at the ground level for facilitating segregation of waste. Solid waste shall be segregated into wet garbage and inert materials.	Noted and being complied.

Status of the Conditions Stipulated in Environment Clearance

S. No.	CONDITION	COMPLIANCE STATUS
iv.	Organic waste compost/ Vermiculture pit/ Organic Waste Converter within the premises with a minimum capacity of 0.3 kg /person/day must be installed.	No canteen facility has been developed inside the premises. Domestic waste (in very small quantity) generated is being managed by local municipality.
v.	All non-biodegradable waste shall be handed over the authorized recyclers for which a written tie up must be done with the authorized recyclers.	Noted.
vi.	Any hazardous waste generated during construction phase, shall be disposed of as per applicable rules and norms with necessary approvals of the State Pollution Control Board.	Noted.
vii.	Use of environment friendly materials in bricks, blocks and other construction materials, shall be required for at least 20% of the construction materials quantity. These include fly ash brick, hollow bricks, MCs, Fly Ash Lime Gypsum block, compressed earth blocks and other environmentally friendly materials.	Noted and being complied.
viii.	Fly ash should be used as building material in the construction as per the provisions of Fly Ash Notification of September, 1999 and amended as on 27th August, 2003 and 25th January, 2016 Ready mixed concrete must be used in building construction.	Noted and being complied.
ix.	Any wastes from construction and demolition activities related thereto shall be managed so as to strictly conform to the construction and Demolition Rules, 2016.	Noted.
x.	Used CFLs and TFLs should be properly collected and disposed of/sent for recycling as per the prevailing guidelines/rules of the regulatory authority to avoid mercury contamination.	Noted.
VII	Green Cover	
i.	No tree can be felled/ transplant unless exigencies demand. Where absolute	Noted.

Status of the Conditions Stipulated in Environment Clearance

S. No.	CONDITION	COMPLIANCE STATUS
	necessary, tree felling shall be with prior permission from the concerned regulatory authority. Old trees should be retained based on girth and age regulations as may be prescribed by the Forest Department. Plantations to be ensured species (cut) to species (Planted).	
ii.	A minimum of 1 tree for every 80 sqm of land should be planted and maintained. The existing trees will be counted for this purpose. The landscape planning should include plantation of native species. The species with heavy foliage, broad leaves and wide canopy cover are desirable. Water intensive and/or invasive species should not be used for landscaping,	Noted Details enclosed as <i>Annexure I</i> .
iii.	Where the trees need to be cut with prior permission from the concerned local Authority, Compensatory plantation in the ratio of 1:10 (i.e. planting of 10 trees for every 1 tree that is cut) shall be done and maintained. Plantations to be ensured species (cut) to species (planted). Area for green belt development shall be provided as per the details provided in the project document.	Noted.
iv.	Topsoil should be stripped to a depth of 20 cm from the areas proposed for buildings, roads, paved areas, and external services. It should be stock piled appropriately in designated areas and reapplied during plantation of the proposed vegetations on site.	Noted and agreed.
VIII	Transport	
i.	A comprehensive mobility plan, as per MoUD best practices guidelines (URDPFI), shall be prepared to include motorized, non-motorized, public and private networks. Roads should be designed with due consideration for the environment and safety of users. The road system can be designed with these basic criteria:	Noted

Status of the Conditions Stipulated in Environment Clearance

S. No.	CONDITION	COMPLIANCE STATUS
ii.	a. Hierarchy of roads with proper segregation of vehicular and pedestrian traffic	Noted.
iii.	b. Traffic calming measures.	Noted.
iv.	c. Proper design of entry and exit points	Noted.
v.	d. Parking norms as per local regulation	Noted.
vi.	Vehicles hired to bring construction material to the site should be in good condition and should have a pollution check certificate and should conform to applicable air and noise emission standards be operated only during non-peak hours.	Noted and being complied.
IX	Human health issues	
i.	All workers working at the construction site and involved in loading, unloading, carriage of construction material and construction debris or working in any area with dust pollution shall be provided with dust mask	Noted and being complied.
ii.	For indoor air quality the ventilation provisions as per National Building Code of India.	Noted and being complied.
iii.	Emergency preparedness plan based on the Hazard identification and Risk Assessment (HIRA) and Disaster Management Plan shall be implemented.	Noted and being complied. Emergency preparedness plan is available.
iv.	Provision shall be made for the housing of construction labour within the site with all necessary infrastructure and facilities such as fuel for cooking, mobile toilets, mobile, STP, safe drinking water, medical health care, creche etc. The housing may be in the form of temporary structures to be removed after the completion of the project.	Noted and being complied.
v.	Occupational health surveillance of the workers shall be done on a regular basis.	Noted and being complied.
vi.	A First Aid Room shall be provided in the project both during construction and operations of the project.	Noted and being complied.
X	Miscellaneous	

Status of the Conditions Stipulated in Environment Clearance

S. No.	CONDITION	COMPLIANCE STATUS
i.	The project proponent shall prominently advertise it in at least two local newspapers of the District or State, of which one shall be in the vernacular language within seven days indicating that the project has been accorded environment clearance and the details of MoEF&CC/ SEIAA website where it is displayed.	Complied. Details enclosed as Annexure X .
ii.	The copies of the environmental clearance shall be submitted by the project proponents to the Heads of local bodies, Panchayats and Municipal Bodies in addition to the relevant offices of the Government who in turn has to display the same for 30 days from the date of receipt.	Complied. Details enclosed as Annexure X .
iii.	The project proponent shall upload the status of compliance of the stipulated environment clearance conditions, including results of monitored data on their website and update the same on half-yearly basis.	Noted and being complied.
iv.	The project proponent shall submit six-monthly reports on the status of the compliance of the stipulated environmental conditions on the website of the ministry of Environment, Forest and Climate Change at environment clearance portal.	Noted and being complied.
v.	The company shall have a well laid down environmental policy duly approved by the Board of Directors. The environmental policy should prescribe standard operating procedures to have proper checks and balances and to bring into focus any infringements/ deviation/violation of the environmental / forest / wildlife norms / conditions. The company shall have a defined system of reporting infringements / deviation / violation of the environmental / forest / wildlife norms / conditions and / or shareholders / stake holders. The copy of the board resolution in this regard shall be submitted to the MoEF&CC as a part of six-monthly report.	Noted and being complied.

Status of the Conditions Stipulated in Environment Clearance

S. No.	CONDITION	COMPLIANCE STATUS
vi.	A separate Environmental Cell both at the project and company head quarter level, with qualified personnel shall be set up under the control of senior Executive, who will directly report to the head of the organization.	Noted and being complied.
vii.	An action plan for implementing EMP and environmental conditions along with responsibility matrix of the company shall be prepared and shall be duly approved by competent authority. The year-wise funds earmarked for environmental protection measures shall be kept in separate accounts and not to be diverted for any other purpose. Year wise progress of implementation of action plan shall be reported to the Ministry/ Regional Office along with the Six-Monthly Compliance Report	Noted.
viii.	The project proponent shall submit the environmental statement for each financial year in Form-V to the concerned State Pollution Control Board as prescribed under the Environment (Protection) Rules, 1986, as amended subsequently and put on the website of the company.	Noted & being complied
ix.	The project proponent shall inform the Regional Office as well as the Ministry, the date of financial closure and final approval of the project by the concerned authorities, commencing the land development work and start of production operation by the project.	Noted.
x.	The project authorities must strictly adhere to the stipulations made by the State Pollution Control Board and the State Government.	Being complied.
xi.	The project proponent shall abide by all the commitments and recommendations made in the EIA/EMP report, commitment made during Public Hearing and also that during their presentation to the State Expert Appraisal Committee (SEAC)	Being complied.
xii.	No further expansion or modification in the plant shall be carried out without prior	Noted.

Status of the Conditions Stipulated in Environment Clearance

S. No.	CONDITION	COMPLIANCE STATUS
	approval of the Ministry of Environment, Forests and Climate Chang (MoEF&CC).	
xiii.	Concealing factual data or submission of false/ fabricated data may result in revocation of this environmental clearance and attract action under the provisions of Environment (Protection) Act, 1986	Noted.
xiv.	The Ministry may revoke or suspend the clearance, if implementation of any of the above conditions is not satisfactory.	Noted.
xv.	The Ministry reserves the right to stipulate additional conditions if found necessary. The Company in a time bound manner shall implement these conditions.	Noted.
xvi.	The Regional Office of this Ministry shall monitor compliance of the stipulated conditions. The project authorities should extend full cooperation to the officer (s) of the Regional Office by furnishing the requisite data / information/ monitoring reports.	Noted and agreed.
xvii.	The above conditions shall be enforced, inter-alia under the provisions of the Water (Prevention & control of Pollution) Act, 1974, the Air (Prevention & control of Pollution) Act, 1981, the Environment (Protection) Act, 1986 Hazardous and Other Wastes (Management and Transboundary Movement) Rules, 2016 and the Public Liability Insurance Act, 1991 along with their amendments and Rules and any other orders passed by the Hon"ble Supreme Court of India/High Courts and any other Court of Law relating to the subject matter.	Noted.
xviii.	Any appeal against this prior environmental clearance shall lie with the Green Tribunal, if necessary, within a period of 30 days as prescribed under Section 16 of the National Green Tribunal Act, 2010.	Noted.

Annexure I
Plantation Photographs



Plantation Photographs

Annexure II
Storm water layout

NOTE:-
FOR STORM WATER LEVELING G.L.=+197.210 IS CONSIDERED AS (±)00

DRAINAGE PIPE	
1A	150Ø RCC PIPE / SLOPE 200
2A	200Ø RCC PIPE / SLOPE 250
3A	250Ø RCC PIPE / SLOPE 350
A	300Ø RCC PIPE / SLOPE 350
B	450Ø RCC PIPE / SLOPE 500
C	500Ø RCC PIPE / SLOPE 550
D	600Ø RCC PIPE / SLOPE 650
E	700Ø RCC PIPE / SLOPE 750
F	900Ø NP-3 PIPE / SLOPE 950
G	1000Ø NP-3 PIPE / SLOPE 1050
H	1100Ø NP-3 PIPE / SLOPE 1150
I	1400Ø NP-3 PIPE / SLOPE 1350

PLUMBING LEGEND-	
SYMBOL	DESCRIPTION
	STORM WATER LINE
CB-1	CATCH BASIN 600X600MM IN BRICK
CB-2	CATCH BASIN 750X750MM IN BRICK
CB-3	CATCH BASIN 1000X1000MM IN BRICK
CB-4	CATCH BASIN 1200X1200MM IN BRICK
CB-5	CATCH BASIN 1500X1500MM IN BRICK
CB-6	CATCH BASIN 2000X2000MM IN BRICK
CB-6	CATCH BASIN 600X600MM IN RCC
CB-7	CATCH BASIN 750X750MM IN RCC
CB-8	CATCH BASIN 1000X1000MM IN RCC
CB-9	CATCH BASIN 1200X1200MM IN RCC
CB-10	CATCH BASIN 1500X1500MM IN RCC
	DESILTING CHAMBER 1500X2000MM (06 NOS.)
	RAIN WATER HARVESTING PIT 2700MM DIA (27 NOS.)
GL.	GROUND LEVEL
IL.	INVERT LEVEL
CL.	CONNECTION LEVEL

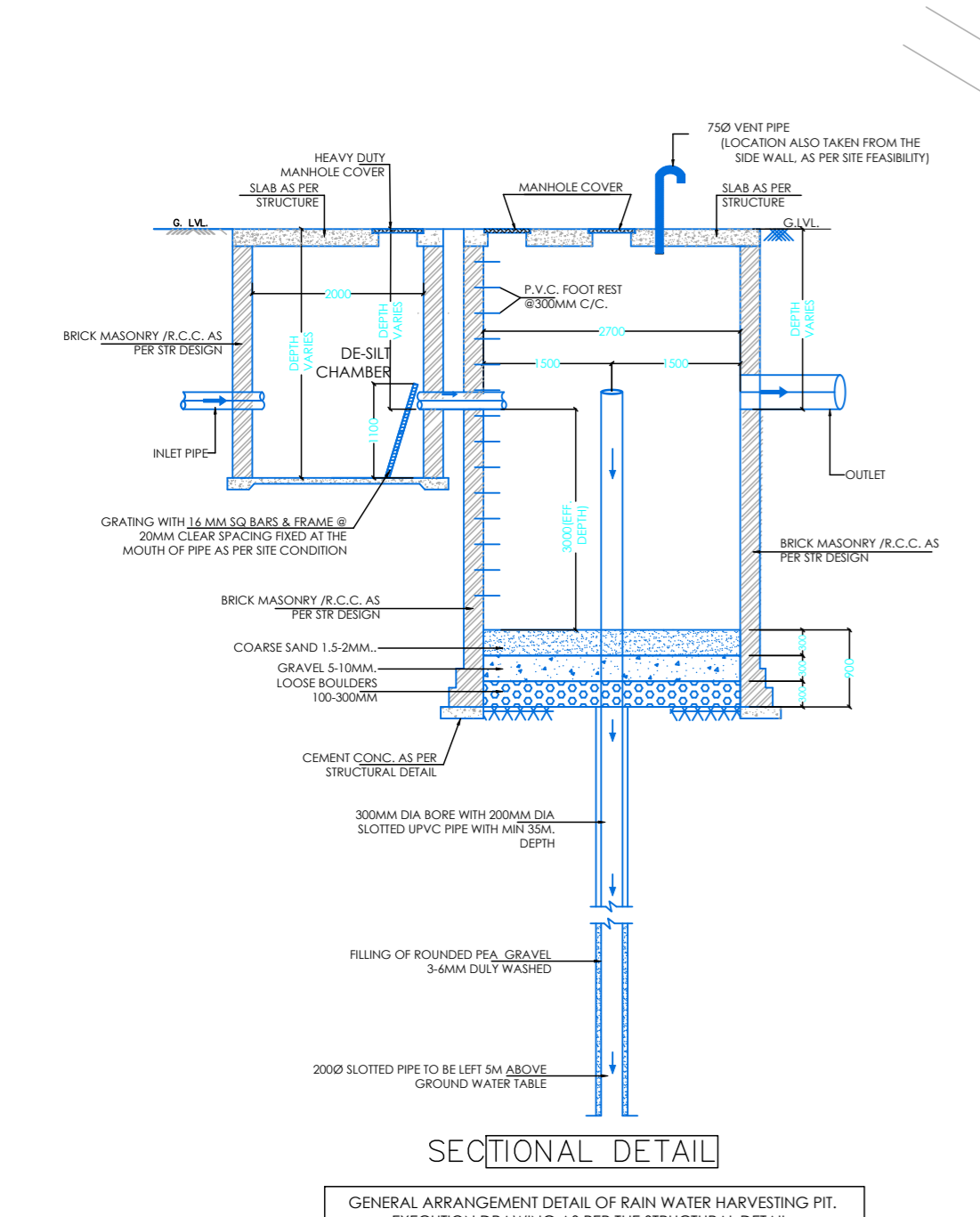
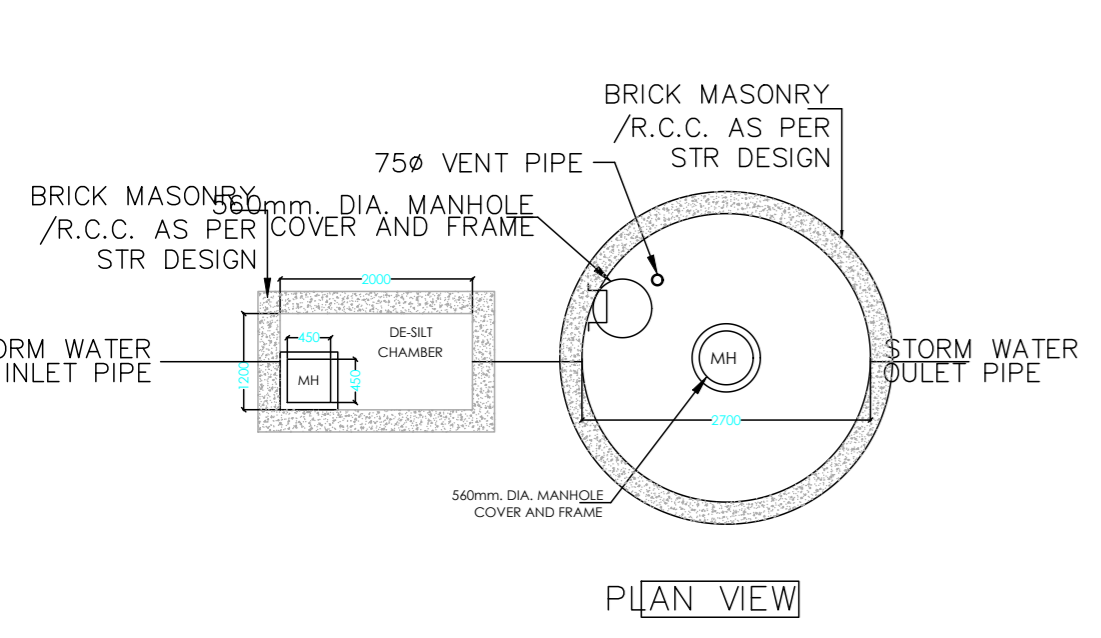

- NOTE
1. STORM WATER LINE UNDER PAVED AREA:- RCC NP-2
 2. STORM WATER LINE UNDER VEHICULAR TRAFFIC AREA:-RCC NP-3
 3. HUME PIPE EQ TO AND ABOVE 900 DIA WILL BE OF NP-3 AT LOCATION.
 4. MEDIUM DUTY MANHOLE COVER FOR NON VEHICULAR MOVEMENT AREA
 5. HEAVY DUTY MANHOLE COVER FOR VEHICULAR MOVEMENT AREA
 6. STORM WATER MANHOLE SHALL BE IN BRICK WORK UNDER PAVED AREA
 7. STORM WATER MANHOLE SHALL BE IN RCC UNDER ROAD/ VEHICULAR TRAFFIC AREA

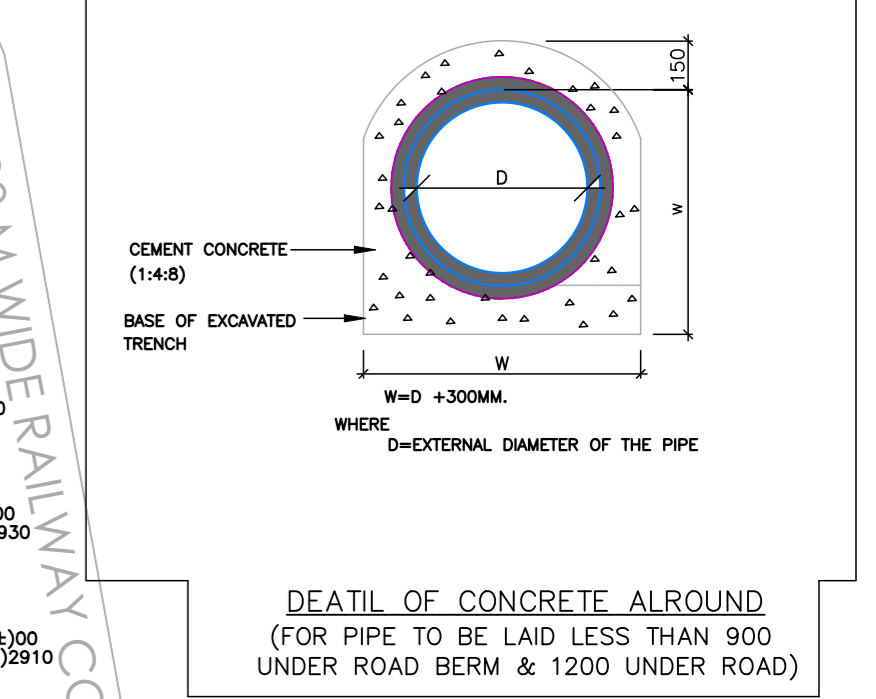
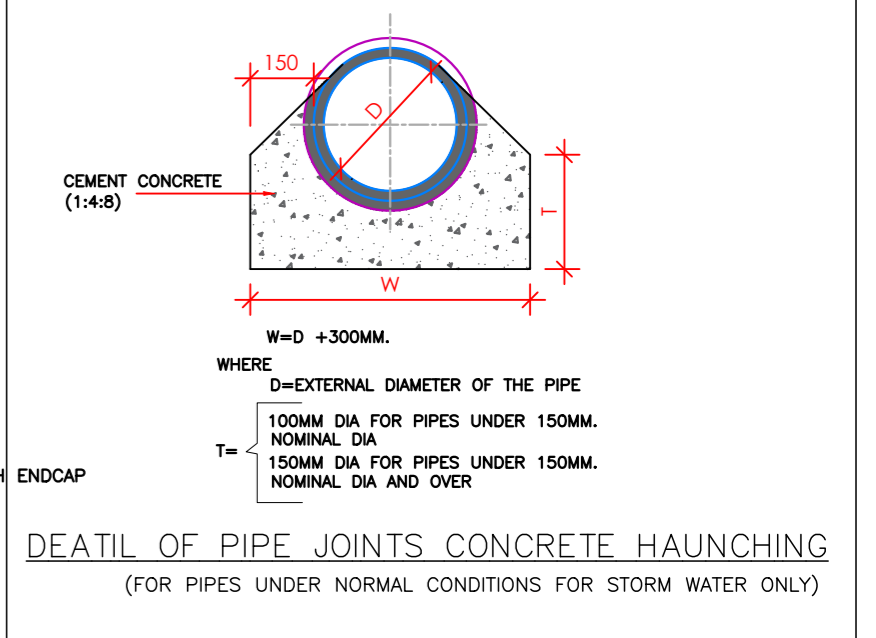
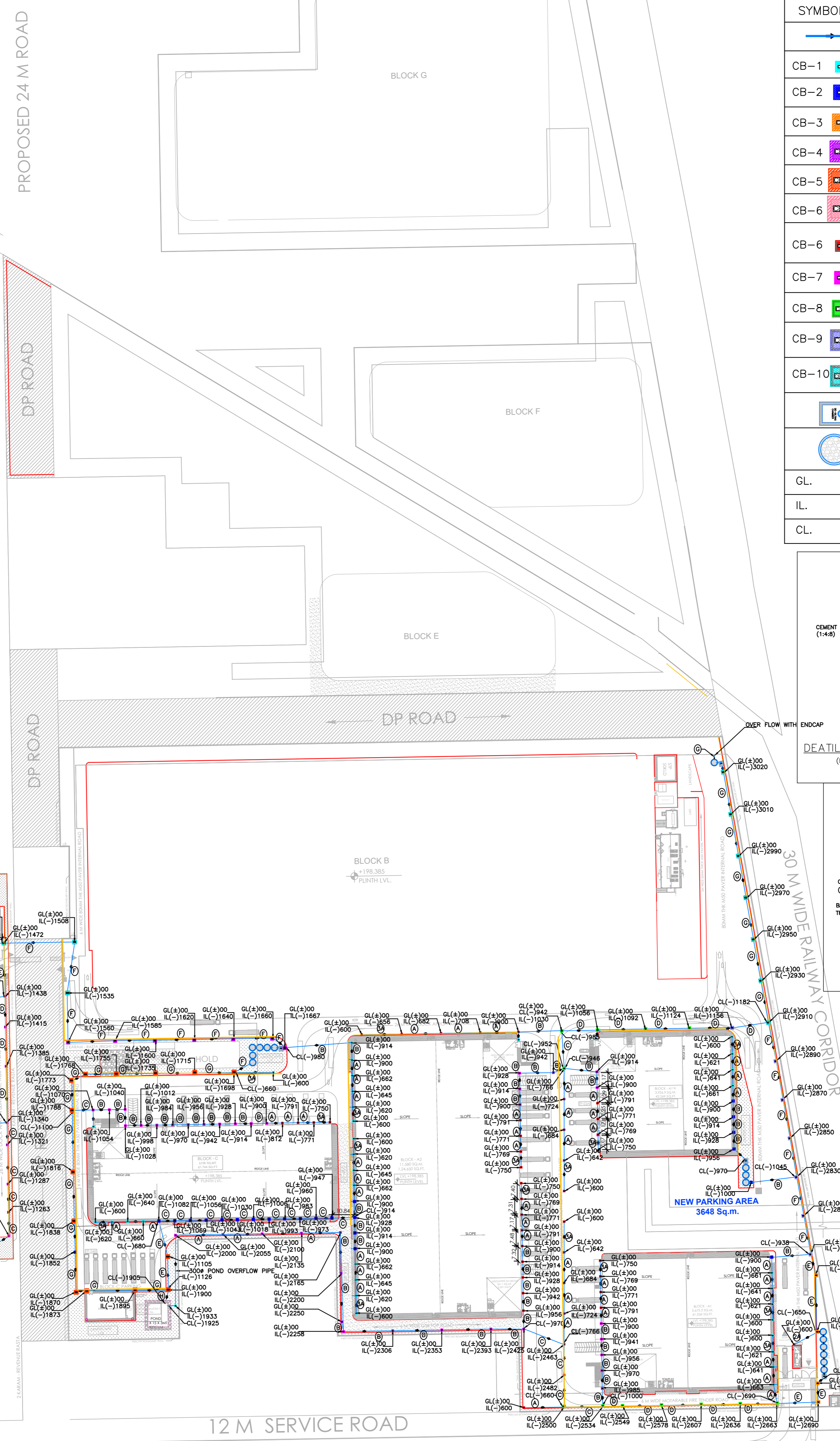

GENERAL NOTES:
1) ALL DIMENSIONS ARE IN METERS UNLESS STATED OTHERWISE.
2) ALL LEVELS SHOWN ARE IN METERS UNLESS STATED OTHERWISE.
3) ONLY THE DIMENSIONS SHOWN BY DIMENSION LINES SHALL BE USED.
4) ALL DIMENSIONS ARE TO FACE UNLESS OTHERWISE SPECIFIED.
5) THE DRAWING SHALL BE READ IN CONJUNCTION WITH ALL RELEVANT SPECIFICATIONS AND DRAWINGS.
6) DISCREPANCIES AND AMBIGUITIES SHALL BE REPORTED TO THE ARCHITECT IMMEDIATELY UPON DISCOVERY.
7) THE CONTRACTOR SHALL BE RESPONSIBLE FOR OBTAINING ALL NECESSARY PERMITS AND APPROVALS FROM THE LOCAL AUTHORITIES.
8) THE CONTRACTOR SHALL BE RESPONSIBLE FOR OBTAINING ALL NECESSARY PERMITS AND APPROVALS FROM THE LOCAL AUTHORITIES.
9) THE CONTRACTOR SHALL BE RESPONSIBLE FOR OBTAINING ALL NECESSARY PERMITS AND APPROVALS FROM THE LOCAL AUTHORITIES.
10) THE CONTRACTOR SHALL BE RESPONSIBLE FOR OBTAINING ALL NECESSARY PERMITS AND APPROVALS FROM THE LOCAL AUTHORITIES.

DATE	REVNO	DESCRIPTION	DATE	REVNO	DESCRIPTION
19-08-2023	A1	STORM WATER LAYOUT REVISED AS PER CLIENT COMMENTS			
14-09-2023	B	STORM WATER LAYOUT REVISED AS PER CLIENT COMMENTS			
19-09-2023	C	STORM WATER LAYOUT REVISED AS PER CLIENT COMMENTS			
28-11-2023	D	STORM WATER LAYOUT REVISED AS PER CLIENT COMMENTS			

CLIENT	BLUE STAR REALTORS PVT LTD
PROJECT	EPC CONTRACT OF WAREHOUSE AND ALLIED FACILITIES AT PALWAL, HARYANA
TITLE	SITE PLAN STORM WATER LAYOUT PLAN
PROJECT NO.	104
SCALE	1:100
DATE	19-08-2023
DRAWN BY	MAHENDRA
CHECKED BY	ANJAN SONIA
APP BY	SA
TENDER	APPROVAL
INFORMATION	CONSTRUCTION
APPROVED	

STRUCTURAL & MEP CONSULTANTS:	PC DESIGNS PRIVATE LIMITED ARCHITECTS ENGINEERS PLANNERS 340, SULTANPUR, M.G. ROAD, NEW DELHI-110030
NORTH DIRECTION	
EPC CONTRACTOR	PISL
DESIGN CONSULTANTS:	CORESCAPE DESIGN STUDIO LLP P-31, SECTOR - 38, GURGAON

APPROVED

104 A1 ADN-EXT-SITE-STM-104-1001

19-08-2023

MAHENDRA ANJAN SONIA

SA

APPROVAL CONSTRUCTION

PC DESIGNS PRIVATE LIMITED ARCHITECTS ENGINEERS PLANNERS 340, SULTANPUR, M.G. ROAD, NEW DELHI-110030

PISL

CORESCAPE DESIGN STUDIO LLP P-31, SECTOR - 38, GURGAON

Annexure III
Solar System installation approval

Shri Brahmant Kumar

DAKSHIN HARYANA BIJLI VITRAN NIGAM LIMITED
(A Power Distribution & Retail Supply Utility, Govt. of Haryana)
Office of Executive Engineer (Operation) Division, DHBVN
Address: Near 66 KV Substation, New Colony Road, Palwal
E-mail xenoppalwal@dhbvn.org.in Phone: 01275-252105
Head Office: - Vidyut Sadan, Vidyut Nagar, Hlsar-125005 (HR)
CIN: U99999HR1999SGC034165, Website: - www.dhbvn.org.in



DHBVN

Memo No.

18232

/Solar Net

Dated 3-1-2025

To.

SDO (OP) S/U S/Divn.,
DHBVNL, Palwal

Sub: - Approval for installation of Rooftop solar PV System to M/s Blue Star Relators Ltd., Village Firojpur, Railway Line, Palwal of applied vide application no F42-1124-11024-1 dated 04.11.2024.

Ref:-

1. Technical Feasibility report in respect of the above referred application along with the recommendations received from your office through online on dated 28.11.2024.
2. Subsequent upon which the required documents completed by the applicant on dated 01.01.2025 as required by this office vide memo no. 16521 dated 21.11.2024 and further remainder through mail on dated 29.11.2024 & 19.12.2024.

Refer to website portal site of ibid connection, approval is hereby accorded as per your office report submitted on portal against sanctioned applied load 50 kWp in the name of to M/s Blue Star Relators Ltd., Village Firojpur, Railway Line, Palwal of applied vide application no F42-1124-11024-1 dated 04.11.2024, vide applicant A/c no. 5265847256 and connection category HT industry with connected load 1000 KW and CD 1000 KVA. The approval has been given as per direction/clarification telephonically by the SE (OP) Circle Palwal in case of M/s Panchwati Education Trust at Omaxe City, Phase-2, Palwal applied vide A&A no. F41-1123-11023-1 dated 18.11.2023.

Further, action shall be taken as per the latest prevailing instruction of the Nigam and as per sales circular no. D-06/2020 dated 28.03.2020, 31/2021 dated 20.08.2021, 04/2023 dated 03.01.2023 & 20/2024 dated 17.07.2024. This approval shall stand cancelled in case of any violation of Nigam instruction by applicant.

Xen (OP) Divn.
DHBVNL, Palwal

Cc:-

1. SE (OP), Circle, DHBVN, Palwal for information please.
2. M/s Blue Star Relators Ltd., Village Firojpur, Railway Line, Palwal of applied vide application no F42-1124-11024-1 dated 04.11.2024 for information and necessary compliance of prevailing Nigam instructions/circulars. This approval shall stand cancelled in case of any violation of Nigam instructions by you.



**Office Of The
Executive Engineer, Electrical Inspectorate, Haryana,
Block C-2, Sushant Lok-I Huda, Primary School Building,
Gurugram-II (E-mail: xenceiggn002@gmail.com)
Website: www.ceiharyana.com**

To

**MS BLUE STAR REALTORS LIMITED
VILLAGE FIROZPUR NEAR RAILWAY LINE PALWAL
PALWAL, HARYANA-122102**



Application No. : 1036488

Application Date: 01/12/2025

Memo No. H.T.I : Palwal/014437/2025

Approval Date: 05/12/2025

Sub:-

Inspection of the following installation/s under Central Electricity Authority (Measures relating to Safety and Electric supply) Regulations, 2023.

S.No.	Installation Type	Capacity
1	Generating Set-1 (Solar Power Plant)	250.00 KWp

The above mentioned installation/s was/were inspected by this Department and the same was/were found generally complying with the relevant provisions of CEA (Measures Relating to Safety and Electric Supply) Regulations, 2023. However, it is advised that:-

All open edges of the roof shall be provided with proper barricading or railings of for safety during installation and maintenance. All metallic structures and module frames shall be properly earthed. Cables shall be laid through trays, and standard danger signage displayed near electrical equipment. Suitable lightning protection and fire extinguishers shall be provided, and safe walkways ensured for maintenance

Approval for energization of the subject cited installation/s is/are hereby accorded subject to consistent compliance of the relevant provisions of CEA (Measures Relating to Safety and Electric Supply) Regulations, 2023 may be ensured in these installations at your end. Please note that it shall be the responsibility of the owner of the electrical installations to maintain and operate the installations in a condition free from danger and as recommended by the manufacturer or by the relevant code of practice of the bureau of Indian Standards.

**Assistant Engineer
Electrical Inspectorate, Haryana,
Gurugram-II**

Shri Brahmant Kumar

DAKSHIN HARYANA BIJLI VITRAN NIGAM LIMITED
(A Power Distribution & Retail Supply Utility, Govt. of Haryana)
Office of Executive Engineer (Operation) Division, DHBVN
Address: Near 66 KV Substation, New Colony Road, Palwal
E-mail xenoppalwal@dhbvn.org.in Phone: 01275-252105
Head Office: - Vidyut Sadan, Vidyut Nagar, Hlsar-125005 (HR)
CIN: U99999HR1999SGC034165, Website: - www.dhbvn.org.in



DHBVN

Memo No.

18232

/Solar Net

Dated 3-1-2025

To.

SDO (OP) S/U S/Divn.,
DHBVNL, Palwal

Sub: - Approval for installation of Rooftop solar PV System to M/s Blue Star Relators Ltd., Village Firojpur, Railway Line, Palwal of applied vide application no F42-1124-11024-1 dated 04.11.2024.

Ref:-

1. Technical Feasibility report in respect of the above referred application along with the recommendations received from your office through online on dated 28.11.2024.
2. Subsequent upon which the required documents completed by the applicant on dated 01.01.2025 as required by this office vide memo no. 16521 dated 21.11.2024 and further remainder through mail on dated 29.11.2024 & 19.12.2024.

Refer to website portal site of ibid connection, approval is hereby accorded as per your office report submitted on portal against sanctioned applied load 50 kWp in the name of to M/s Blue Star Relators Ltd., Village Firojpur, Railway Line, Palwal of applied vide application no F42-1124-11024-1 dated 04.11.2024, vide applicant A/c no. 5265847256 and connection category HT industry with connected load 1000 KW and CD 1000 KVA. The approval has been given as per direction/clarification telephonically by the SE (OP) Circle Palwal in case of M/s Panchwati Education Trust at Omaxe City, Phase-2, Palwal applied vide A&A no. F41-1123-11023-1 dated 18.11.2023.

Further, action shall be taken as per the latest prevailing instruction of the Nigam and as per sales circular no. D-06/2020 dated 28.03.2020, 31/2021 dated 20.08.2021, 04/2023 dated 03.01.2023 & 20/2024 dated 17.07.2024. This approval shall stand cancelled in case of any violation of Nigam instruction by applicant.

Xen (OP) Divn.
DHBVNL, Palwal

Cc:-

1. SE (OP), Circle, DHBVN, Palwal for information please.
2. M/s Blue Star Relators Ltd., Village Firojpur, Railway Line, Palwal of applied vide application no F42-1124-11024-1 dated 04.11.2024 for information and necessary compliance of prevailing Nigam instructions/circulars. This approval shall stand cancelled in case of any violation of Nigam instructions by you.

Annexure IV
Town Planning Approval



FORM BR- III

(See code 4.2(4))

Form of sanction

To

M/s Adani Logistics Limited,
Adani Corporate House,
Shantigram, Nr. Vaishno Devi Circle,
S.G. Highway, Khodiyar, Ahmedabad- 382421.

Memo No. DULB/CTP/CLU-39 PWL/2023/420

Dated: 23/01/2024

Subject: Approval of Building Plans in respect of Industrial and Warehouse (Agro as well as Non-Agro) purpose over land falling in the revenue estate of village Ferozpur, Industrial Sector-22, Tehsil & District Palwal- M/s Adani Logistics Limited.

1. Please refer to your application dated 27.04.2023 for sanction of building plans over land, which the CLU permission was granted by this office vide memo dated 21.04.2023 for setting up of Industrial & warehouse (Agro as well as Non-agro produce) over land measuring 217386.19 sq. mtrs. (after excluding area measuring 50816.84 sq.mtrs falling under 45 & 30 mtr wide sector road under 24 mtr circular road and 12 mtr service road and area under surface parking), falling in the revenue estate of village Ferozpur, Industrial Sector-22, Tehsil & Distt. Palwal Situated within the limits of Municipal Council, Palwal.
2. The building plans for the aforesaid construction are hereby sanctioned subject to the provisions of the Haryana Municipal Act, 1973 and subject to the following conditions:
 - i. That you will comply with all terms & conditions of the permission for change of land use issued by this office vide memo no. DULB/CTP/CLU-39 PWL/2023/3297 dated 21.04.2023.
 - ii. The plans are valid for a period of 2 years for the buildings less than 15.00 meters in height and 5 years for the multi-storied buildings from the date of issuance of sanction, subject to validity of change of land use permission for this scheme.
 - iii. The structural responsibility of the construction shall be entirely of the owner/supervising architect/Engineer of the Scheme.

Further that:-

- (a) The building shall be constructed as per the provisions of NBC and relevant IS code for all seismic loads, all dead and live loads, wind pressure and structural safety from earthquake of the intensity expected under zone-IV.
- (b) All material to be used for erection of building shall conform to I.S.I and N.B.C standards.
- (c) No walls / ceiling shall be constructed of easily inflammable material and stair cases shall be built of the fire resisting material as per standard specification.
- (d) The roof slab of the basement external to the buildings if any, shall be designed / constructed to take the load of fire tender up to 45 tones.

- (e) You shall submit certificate on prescribed format as per Form BR-VA (2) regarding structural stability and earthquake resistance, alongwith structural drawings, duly signed by Structural Engineer within 60 days alongwith structural drawing for record.

3. FIRE SAFETY

- (i) The applicant and the supervising Architect of the project shall be entirely responsible for making provisions of fire safety and firefighting measures and shall abide by all fire safety bye laws.
- (ii) Further, No objection granted by the Deputy Director, O/o Directorate Fire Services, Haryana, Panchkula vide their Memo no. DFS/SF/2023/1178/6528 dated 26.07.2023, for approval of building plans (architecture point of view only) subject to the condition that;

"The firm shall submit a detailed firefighting scheme as per National building Code of India 2016 Part-IV, within 90 days from the date of issuance of building plan approval or before start of construction, clearly showing the provisions mentioned in the National Building Code, 2016 Part-IV with questionnaire, DBR of Fire, ventilation and electric system etc. and get approved the same from the Director, Fire Services, Haryana Panchkula, Haryana concerned local authority as per Haryana Fire and Emergency Services Act-2022 and direction issued time to time if any."

Therefore you shall follow the terms and conditions of Memo no. DFS/SF/2023/1178/6528 dated 26.07.2023.

4. No addition and alteration in the building plan/layout plan shall be made without the prior approval of Director, Urban Local Bodies, Haryana, Panchkula.
5. If any infringement of bye- laws remains un-noticed, the Department reserves right to amend the plan as and when any such infringement comes to the notice after giving an opportunity of being heard and the department shall stand indemnified against any claim on this account.
6. The layout showing the electric installation shall have to be got approved from the Chief Electrical Inspector, Haryana before execution of work at site.
7. No person shall occupy or allows any other person to occupy any new building or part of the same for any purpose what so ever until such building or part thereof has been certified by the Director or any person authorized by him in this behalf as having been completed in accordance with the permission granted and an occupation certificate on prescribed form has been duly issued in your favour.
8. That you will inform the DTP, Palwal/Executive Officer, Municipal Council, Palwal at least seven days earlier before the commencement of construction at site indicating the date and time of commencement of the erection of building.
9. That you will obtain DPC certificate from the Architect through self-certification and shall submit the same in the office of DTP, Palwal/Executive Officer, Municipal Council, Palwal before raising construction above DPC level.
10. The open parking around the building blocks shall be mettalled and properly organized.
11. That for obtaining occupation certificate, you shall have to submit a notice of completion of the building in as per prescribed format of HBC-2017 regarding

completion of works described in the plans along with following within the validity period of building plans:

- a. A clearance from the fire safety point of view from Fire Station Officer, Palwal.
- b. Structural stability certificate from qualified structure engineer on Form BR-V-A(1).

12. WATER SUPPLY

- (i) You will make your own arrangement of potable water for adequate or constant and reliable water supply as required under the rules.
- (ii) The down take system shall be provided by providing clear water storage tank of not less than half day requirement of water for usages on the top of building block. The capacity of the tank as shown on the plans and down take system/thereof are as under:
 - (a) Inlet pipe from down take to toilet shall be 15 mm dia shown on the plans and connection pipe in each individual fixture shall be 15 mm dia or above.
- (iii) You shall also engage a qualified Public Health Engineer as consultant for the project.
- (iv) All plumbing pipes fitting, valves will be red colour or painted red. In case of embedded pipes, market tapes of red colour at suitable intervals shall be fixed. The underground and overhead tanks should have "Recycle water not fit for drinking" and other warning signs embossed/marked on them.

13. Sewerage:

- (i) All sewerage lines should not be less than 200 mm dia SW pipes.
- (ii) All soil stacks shall be 100 mm dia and all waste stacks shall be 100 mm dia. Waste water pipe connecting Floor Trap (FT) to Gully Trap (GT) and FT to waste water stack shall be 75 mm dia.
- (iii) All W.C. shall be provided with high /low levels flushing cistern. It shall be mandatory for the firms to provide dual/ two button flush system in toilets. The capacity of flushing cistern shall be 8 liters for full discharge/ 3 liters for half discharge.
- (iv) You have proposed disposal of sewerage through proposed STP/Septic Tank for zero discharge thus it is made clear that you shall provide the same as per IS norms and there will be no pollution due to sewerage.
- (v) You will make suitable arrangement for disposal of the effluent in accordance with CPCB/MoEF and take the due consent to establish and operate from HSPCB/CPCB ensuring zero discharge.

14. Storm Water Drainage:

- (i) All external storm water drainage shall be provided suitably so as the disposed of rain water in to external system of the Town.
- (ii) The Rain Water harvesting system shall be provided as per central ground water authority norms/Haryana Govt. notification as applicable.
- (iii) Total runoff of the rain water i.e. roof top runoff and also paved area runoff along with capacity of recharge to be calculated.
- (iv) All rain water stacks shall be as shown on the plans. It is made clear to you that roof top rain harvesting system shall be provided as per Central Ground Water Authority norms/Haryana Govt. Notification as applicable and shall be kept operational all the time.

15. Solid Waste Management:-

- (i) The building proposed for construction comes under bulk waste generator category so the agency shall comply with the Solid Waste Management Rules-2016 and relevant guidelines issued by HSPCB, CPCB & Hon'ble NGT from time to time.
- (ii) The directions issued by the Hon'ble NGT shall be strictly complied with.

16. GENERAL:-

- i. Recycled water is proposed to be utilized for flushing purposes. The firm has made provision of separate flushing line, storage tank, metering system, pumping system and plumbing. It may be clarified to developer that no tap or outlet of any kind will be provided from the flushing lines/plumbing lines for recycled water except for connection to the cistern of flushing tanks and any scouring arrangement. Even ablution taps should be avoided.
- ii. Alternative source of electricity shall be provided by the firm for functioning of water supply, sewerage, SWD, scheme by providing Gen. St of required capacity.
- iii. All pipes, fixture fitting pumps, Gen. set and filtration plans etc. shall be conforming to relevant IS specification and ISI marked.
- iv. No cross connection between recycled water system and potable water system shall be made.
- v. All plumbing pipes fitting, valves will be red colour or painted red. In case of embedded pipes, market tapes of red colour at suitable intervals shall be fixed. The underground and overhead tanks should have "Recycle water not fit for drinking" and other warning signs embossed/ marked on them.
- vi. Recycled water pipes and potable water pipes will be fixed in separate chases and a minimum horizontal distance of 6" (150mm) will be maintained between them. In case of cross suitably colored/taped sleeve shall be used.
- vii. The applicant will provide appropriate pipes (both up and down) for solar water heating system.
- viii. All pipes, Fixture, fittings, Pumps, Generator set and filtration plant etc. shall be conforming to relevant IS specification and ISI marked.
- ix. The company will have to pay the proportionate cost of external development charges for water supply, sewerage, storm water drainage, roads, bridges, community building, street lighting, Horticulture etc. on gross average basis as and when determined by HSVP/State Govt. and will binding upon the firm.
- x. The applicant will be solely responsible for making connection with the master services, if provided by the State Govt./HSVP at their cost with the prior approval of the competent authority.
- xi. The correctness of the levels of the building will be sole responsibility of the applicants for integrating the internal sewer/SWD of the university by gravity.
- xii. That the Solar Photovoltaic Power Plant shall be provided as per the norms specified by HAREDA and the instructions issued by Urban Local Bodies Department vide orders issued on 12.10.2015 shall be made operational in the building, before applying for an occupation certificate. Further the owner shall ensure the installation of Light-Emitting Diode lamps (LED) for its campus as well as building.
- xiii. The provisions of ECBC as per notification no. 19/6/2016-SP dated 31.3.2016 shall be mandatory in the building . The compliance shall be done by

submitting a certificate issued by a Registered Architect confirming that the building plans confirm to the ECBC along with formats prescribed by BEE.

- xiv. The applicant will self-certify completion of building by submitting DPC certificate at DPC level.
17. This sanction shall be void abnatio, if any of the conditions mentioned above are not complied with.
18. The area details for the proposed additional buildings plans being approved are as under:

Total CLU Granted area	2,17,386.19 sq.mtrs.
Permissible Ground Coverage@ 60%)	1,30,431.71 sq. mtrs.
Achieved Ground coverage	1,06,655.65 sqm (49.06 %)
Permissible FAR 75%	1,63,039.64 sqm
Proposed FAR	1,12,095.01 (51.56 %)
Parking Required as per approved zoning clause i.e.15% of total plot area	32607.93 sq.mtrs.
Parking area proposed	33257.53 sq. mtrs. (15.30%)

D.A.: -One set of approved Building Plans.

Director,
Urban Local Bodies,
Haryana, Panchkula

Endst. No. : DULB/CTP/CLU-39 PWL/2023/

Dated:

A copy is forwarded to the following for information and further necessary action:-

1. The District Municipal Commissioner, Palwal.
2. The Director, Renewable Energy Department, Haryana, HAREDA Bhawan, Sector-17, Panchkula.
3. Secretary, Haryana Building and other Construction Workers Welfare Board , Bays no. 29-30, sector-4, Panchkula.
4. Chief Engineer (HQ) Directorate of Urban Local Bodies, Haryana, Panchkula.
5. Joint Director Environment, New Address SCO-123, Sector-17 D, Chandigarh.
6. District Town Planner, Palwal along with one set of sanctioned building plans.
7. Executive Engineer, HSVP Division, Palwal.

-sd-
Assistant Town Planner,
for Director, Urban Local Bodies,
Haryana, Panchkula

Form CLU-III
(See Rule 26-E)

To

M/s Adani Logistics Limited,
Adani Corporate House, Shantigram,
Near Vaishno Devi Circle, S.G Highway, Khodiyar,
Ahmeadabad-382421

Memo no. DULB/CTP/CLU- 39 PWL/2023/3297

Dated: 21/04/2023

Subject:-

Permission for change of land use for setting up of an Industrial & Warehouse (Agro as well as Non-agro produce) over land falling in the revenue estate of village Ferozpur Tehsil & Distt. Palwal - Adani Logistics Limited.

1. The permission for change of land use for setting up of a warehouse (Agro as well as Non-agro produce) over land measuring 217386.19 sq. mtrs. (after excluding area measuring 50816.84 sq.mtrs falling under 45 & 30 mtr wide sector road under 24 mtr circular road and 12 mtr service road and area under surface parking) bearing khasra no. 50//4/1, 6/2/2, 7/2, 8, 12/2, 13, 14, 15/1/1, 16/2/1, 17, 18, 19/1, 19/2, 22/1, 22/2, 23/1, 23/2, 24/1, 24/2, 25/1/1/1, 25/1/1/2, 25/1/2/1, 58//1/1 4/3, 5/1/1, 5/1/2, 6/2/1, 6/2/2, 7/1, 7/2, 8/1, 8/2, 9/1, 9/2, 10, 11/1, 12/1, 12/2, 13/1, 13/2, 13/3, 13/4, 14, 15/1, 16/2, 17/1, 17/2, 18, 19/1, 21, 22/1, 22/2, 23/1/1, 23/1/2, 23/2, 24/1, 24/2, 25/1, 25/2/1, 26, 61//6/2, 14, 15/1, 15/2, 15/3, 16, 17, 24/1, 24/2, 25, 62//1, 2, 3, 4, 5, 6, 7, 8/1, 8/2, 9, 10/1/1, 10/2, 11, 12/1, 12/2, 13/1, 13/2, 14, 15, 16, 17, 18/1, 18/2, 19/1/1, 19/2, 20/1, 20/2, 21, 22/1, 22/2, 23/1, 23/2, 24/1, 24/2, 24/3, 25, 63//10/2, 11/1, 20/2 21, 70//1, 10/1, 10/2/1, 71//1, 3/1, 3/2, 3/3, 4/1, 4/2, 5, 6/1, 6/2/1, 7/1/1, 72//5/1 of revenue estate of village Ferzopur, Tehsil & Distt. Palwal Situated within the limits of Municipal Council, Palwal in Industrial, Sector-22 is hereby granted as per provision under Section 203E (2)(a) of the Haryana Municipal Act, 1973 after receipt of Rs.1,63,03,964/- on account of conversion charges, Rs. 4,20,22,138/- on account of 10% of the gross payable amount of External Development Charges of Rs. 42,02,21,376/-.
2. This permission is further, subject to the following terms & conditions:
 - i. That the conditions of agreement executed by you with the Director, Urban Local Bodies, Haryana, Panchkula and the provisions of the Haryana Municipal Act, 1973 are duly complied with by you.
 - ii. That you shall submit the access permission issued by competent authority (i.e. HSVP) to the Municipal Council, Palwal as well as this office either before approval of Building plan or before issuance of occupation certificate.
 - iii. That you shall pay the additional amount of conversion charges and External Development Charges for any variation in the area of site in lump sum within 30 days or as and when detected and demanded by the Director, Urban Local Bodies, Haryana, Panchkula.

- iv. You shall deposit 40% EDC (updated) shall be deposit before approval of building plans or within six months of grant of CLU permission and the balance 50% (updated) before issuance of Occupation Certificate or within two tears from grant of CLU permission whichever is earlier.
- v. That you shall give at least 75% employment shall be given to the domiciles of Haryana where the posts are of non-technical nature and a quarterly report in this regard shall be submitted to G.M.D.I.C, Palwal.
- vi. That you shall deposit the internal Development charges to HSVP/ Municipal Council, Palwal/ any other agency of the Govt. as and when demanded.
- vii. That you shall get the building plans for the proposed construction at site approved from the Director, Urban Local Bodies before commencement of work and shall start construction at site within six months from issuance of CLU permission.
- viii. That you shall obtain occupation certificate from Director, Urban Local Bodies after completing the building within two years of issuance of the permission.
- ix. That you will pay the labour cess before approval of building plan.
- x. That you shall not object acquisition of land from your site whenever required for road widening in future by any Government agency.
- xi. That the development/ construction cost of 24/18 mtrs. wide road/ major internal road is not included in the EDC rates and you will pay the proportionate cost for acquisition of land, if any along with the construction cost of 24/18 mtr wide road/ major internal road as and when finalised and demanded by Director, Urban Local Bodies, Haryana Panchkula.
- xii. This permission shall be valid for two years from the date of issue of this letter subject to fulfilment of the terms and conditions of the permission granted and agreement executed.
- xiii. That this permission will not provide any immunity from any other Act/Rules/Regulations applicable to the land in question.
- xiv. A copy of the approved Zoning Plan drawing no. DGULB/CTP/2023/15 dated 20.04.2023 is enclosed.



Director General,
Urban Local Bodies, Haryana,
Panchkula.

Endst. no. DULB/CTP/CLU- 39 PWL/2023/

Dated:

A copy is forwarded to the following for information and necessary action:-

- i. The District Town Planner, Palwal alongwith copy of the approved zoning plan drawing no. DGULB/CTP/2023/15 dated 20.04.2023.
- ii. The Executive Officer, Municipal Council, Palwal.
- iii. The Joint Director, Industries & Commerce, Palwal.

Senior Town Planner,
for Director General, Urban Local Bodies,
Haryana, Panchkula

FORM BR-VII
(See code 4.10 (2)(4) and (5))
Form of Occupation Certificate

Memo no. DULB/CTP/CLU-39 PWL/2024/ 4582

Dated: 18/01/2024

To

M/s Adani Logistics limited,
Adani Corporate House,
Shantigram, Nr. Vaishno Devi Circle,
S.G.Highway, Khodiyar, Ahmedabad-382421.

Subject: Issuance of part Occupation Certificate in respect the Industrial & Warehouse (Agro as well as Non-Agro produce) Unit over land falling in the revenue estate of Village Ferozpur, Industrial Sector-22, Tehsil & District Palwal- M/s Adani Logistics Limited.

Whereas you have applied for issuance of the part Occupation Certificate in respect of the building described below, I hereby grant permission for the occupation of the building after considering, NOC regarding fire safety issued by Director General, Fire Service, Haryana, vide memo no. FS/2024/761 dated 08.07.2024, structure stability certificate issued by Mr. T.D. Aneja, report of Chief Engineer (HQ), Report of District Town Planner, Palwal, after receipt of composition charges Rs. 4,66,476/- and as per recommendation of BPAC.

This permission shall be further subject to the following conditions:

1. That the building shall be used for the purpose for which the occupation certificate is being granted i.e. for Industrial & Warehouse (Agro as well as non-agro produce) Any violation of this condition shall render this occupation certificate null and void.
2. That all the terms and conditions of change of land use permission granted by this office vide memo no. DULB/CTP/CLU-39PWL/2023/3297 dated 21.04.2023, shall be duly complied with by you.
3. That you shall be fully responsible with regard to the structural and fire safety measures.
4. That you shall be solely responsible for making your own arrangement for providing water supply, disposal of sewerage and storm water of the scheme.
5. That you shall maintain roof top rain water harvesting system properly and keep it operational all the time.
6. That you shall also ensure the compliance & directions of Hon'ble NGT/CPCB/HSPCB & any other court regarding management of solid waste, Biomedical waste, Liquid waste Air pollution. In any other case, any deficiency found in compliance at any stage you shall be personally responsible for that.
7. That the outer facade of the building shall not be used for the purpose of advertisement and placement of hoardings.
8. That you shall neither erect or allow the erection of any communication and transmission tower on the top of the building block.
9. That you shall use Light Emitting Diode Lamps (LED) in the building as well as street lighting.
10. That you shall not raise any further construction without getting the building plans approved from this Directorate.
11. That no vehicle shall be allowed to be parked on road or public open space.
12. That you shall ensure compliance of ECBC norms.

13. That you shall install the EV charging points as per the prevailing policy of the Government from time to time.
14. That you shall comply with all the conditions laid down in the memo of Director General, Fire Service, Haryana, vide memo no. FS/2024/761 dated 08.07.2024, with regard to fire safety measures and you shall be fully responsible for fire safety measures.
15. That the Solar Photovoltaic Power Plant shall be operational in the building as per the norms specified by HAREDA.

Now the part Occupation certificate is hereby granted details of which is as under;

1.	Total CLU granted area	217386.19 sq. mtrs.
2.	Permissible Ground Coverage (60%)	130431.71 Sq. mtrs.
3.	Ground Coverage Achieved (20.76%) (in order)	45,129.102 Sq.mtrs.
4.	Total Permissible FAR (75%)	1,63,039.64 Sq. mtrs.
5.	FAR Achieved (21.84%) (in order)	47478.142 Sq. mtrs.
6.	Construction area on Mezzanine floor	2349.04 Sq. mtrs.
7.	Total covered area (FAR+ Non-FAR area)	47478.142 Sq. mtrs.

DESCRIPTION OF BUILDING

Part Occupation Certificate for Industrial & Warehouse (Agro as well as non-agro produce) for which the details of the area are as follow;

Sr. no.	Floor	FAR (Sq. mtrs.)	Non-FAR (Sq. mtrs)	Built up Area (Sq. mtrs)
1.	Ground Floor i. Shed Blocks A-1, A-2, A-3, C&D ii. Driver Room-1&2 iii. LT Room & Pump Room iv. Security Office + Meter Room	i. 44219.318 ii. 2349.28 iii. 388.616 iv. 53.888	-	45,129.102
2.	Mezzanine Floor Shed Blocks A-1, A-2, A-3, C&D	2349.04	-	2349.04
Total built up area		47478.142	-	47478.142



Director,
Urban Local Bodies,
Haryana, Panchkula.

Endst. No. DULB/CTP/CLU-39 PWL/2024/

Dated:

A copy of the above is forwarded to the following for information and necessary action:

- 1 District Municipal Commissioner, Palwal.
- 2 District Town Planner, Palwal. In reference to their memo no.1867 dated 04.05.2024.
- 3 Deputy Director, Fire Service, Haryana in reference to the Fire NOC issued vide memo No. FS/2024/761 dated 08.07.2024.



Assistant Town Planner,
for Director, Urban Local Bodies,
Haryana, Panchkula.

Annexure V
Structural Stability Certificate

Letter of Certification – Design & Stability

Everest Reference/Job No.: **PB-02426- A1**

Project: **M/s. Pragati Infra solution pvt ltd, Alapur, Palwal, Haryana**

Building usage: **Warehouse**

Customer: **M/s. Pragati Infra solution pvt ltd**

Address: **31-P, Sector 38, Gurugram, Haryana - 122003**

Customer PO No. and Date:

PO- **PISL/22-23/PLWL/0076**

Dated - **09.09.2023**

WO- **PISL/22-24/PLWL/0077**

Dated - **09.09.2023**

Completion Certificate No. and Date: **CC/PB-02426**

This is to certify that the above referenced project has been designed in accordance with the applicable portions of the Building Code specified below. All loading and building design criteria shown have been specified by contract and applied in accordance with the building code.

Loads and codes – Building –Block-A1

Job site: **Palwal, Haryana**

Building Code: **NAUS/AISI-2012 (LRFD)**

Built-up Design Code: **AISC-2016 (LRFD)**

Rainfall: **150 mm/hr.**

Cold form Design Code: **NAUS/AISI-2012 (LRFD)**

Concrete Characteristics Strength: **M25**

Seismic Code: **IS 1893-2016(Part-1)**

Wind Load: **IS-875:2015 (Part-3)**

Dead and Collateral Loads

Dead Load: Roof covering + secondary + Frame weight

- **0.12 KN/Sq.m. for purlin design**
- **0.20 KN/Sq.m. for primary members**

Roof Live Load

Roof Live Load: **0.57 KN/Sq.m.**

Additional Loads

- **0.25 KN/Sq.m. on purlin design**
- **0.35 KN/Sq.m. on primary members**
- **400 KG/Rmt load on jackbeam**
- **75 KG-M torsional moment on all jack beams.**
- **200 KG/Rmt load on cable tray @ 750mm brackets on 2 levels (Refer GAD for location)**
- **25° c Temperature load on column and rafters.**

Wind Load

Wind speed: **47 m/sec (Exposure -B, Category-II)**

Wind Enclosure /permeability: **Medium permeability**

Wind Importance factor: **1.0**

Seismic Load

Seismic Zone: **IV**

Seismic Importance factor: **1.2**

Response reduction factor: **3**

Soil Profile/type: **SS / ST -3**

Damping factor: **5 %**

Mezzanine Loads

Mezzanine 1

Dead Load: **4.125 KN/Sq.m.**

Live Load: **4.5 KN/Sq.m.**

Mezzanine Grid: **GL-(A TO C) & (W TO Y), GL-(1 TO 3)**

Regd. Office GAT No. 152 Lakhmapur Taluka Dindori Nashik 422 202 Maharashtra Tel +91 2557 250375/462

Fax +91 2557250376

Corporate Identity Number: L74999MH1934PLC002093

BUILDING SOLUTIONS | ROOFING | WALLS | CEILINGS | CLADDING | STEEL BUILDINGS

Building design loads and governing building code is provided by the Customer and is not validated by Everest Industries Limited. The customer is responsible for contacting the local consultant / architect or project Design Professional to obtain all code and loading information for this specific building site.

This certificate qualifies when actual loads on the structure do not exceed the design loads mentioned above under any circumstances, building enclosure does not change due to addition/deletion of openings or any other modifications, no alterations / additions are made to the building without written consent of Everest Industries Limited and building has been maintained as per the building maintenance manual.

This certification DOES NOT apply to the design of the foundation or other on-site structures or components not supplied by Everest Industries Limited, nor does it apply to unauthorised modifications to building components. Furthermore, it is understood that certification is based upon the premise that all components will be erected or constructed in strict compliance with pertinent latest controlled documents of this project. Everest Industries Limited DOES NOT provide general review of erection during or after building construction unless specifically agreed to in the contract documents.

This certification is valid for 20 years. Further extension of stability will be issued for a period of 5 years each time till 50 years with a pre-condition of conducting a joint inspection (from either side) for assessing the building for

- Any physical damage
- Modification carried out on the structure overlooking the design conditions during the period of existence since it is handed over.
- Any deterioration caused in the structure owing to improper maintenance or any Natural calamities.
- modification carried out without our notice of Everest
- Physical Damage to the structure

For Everest Industries Limited

A handwritten signature in blue ink is written over a circular blue stamp. The stamp contains the text "EVEREST INDUSTRIES LIMITED" around the perimeter and a small star in the center. The signature is written across the top half of the stamp.

Date: 19th November 2024

General Manager – Engineering and Design

Regd. Office GAT No. 152 Lakhmapur Taluka Dindori Nashik 422 202 Maharashtra Tel +91 2557 250375/462

Fax +91 2557250376

Corporate Identity Number: L74999MH1934PLC002093

BUILDING SOLUTIONS | ROOFING | WALLS | CEILINGS | CLADDING | STEEL BUILDINGS

Letter of Certification – Design & Stability

Everest Reference/Job No.: PB-02426- A2
 Project: M/s. Pragati Infra solution pvt ltd, Alapur, Palwal,
 Haryana
 Building usage: Warehouse

Customer: M/s. Pragati Infra solution pvt ltd
 Address: 31-P, Sector 38, Gurugram, Haryana -
 122003

Customer PO No. and Date:
 PO- PISL/22-23/PLWL/0076 Dated - 09.09.2023
 WO- PISL/22-24/PLWL/0077 Dated - 09.09.2023

Completion Certificate No. and Date: CC/PB-02426

This is to certify that the above referenced project has been designed in accordance with the applicable portions of the Building Code specified below. All loading and building design criteria shown have been specified by contract and applied in accordance with the building code.

Loads and codes – Building –Block-A2

Job site: Palwal, Haryana	Building Code: NAUS/AISI-2012 (LRFD)
Built-up Design Code: AISC-2016 (LRFD)	Rainfall: 150 mm/hr.
Cold form Design Code: NAUS/AISI-2012 (LRFD)	Concrete Characteristics Strength: M25
Seismic Code: IS 1893-2016(Part-1)	
Wind Load: IS-875:2015 (Part-3)	

Dead and Collateral Loads

Dead Load: Roof covering + secondary + Frame weight

- 0.12 KN/Sq.m. for purlin design
- 0.20 KN/Sq.m. for primary members

Roof Live Load

Roof Live Load: 0.57 KN/Sq.m.

Additional Loads

- 0.25 KN/Sq.m. on purlin design
- 0.35 KN/Sq.m. on primary members
- 400 KG/Rmt load on jackbeam
- 75 KG-M torsional moment on all jack beams.
- 200 KG/Rmt load on cable tray @ 750mm brackets on 2 levels (Refer GAD for location)
- 25° c Temperature load on column and rafters.

Wind Load

Wind speed: 47 m/sec (Exposure -B, Category-II)
 Wind Enclosure /permeability: Medium permeability
 Wind Importance factor: 1.0

Seismic Load

Seismic Zone: IV
 Seismic Importance factor: 1.2
 Response reduction factor: 3
 Soil Profile/type: SS / ST -3
 Damping factor: 5 %

Mezzanine Loads

Mezzanine 1	Dead Load: 4.125 KN/Sq.m.	Live Load: 4.5 KN/Sq.m.	Mezzanine Grid: GL-(A TO C) & (R TO T), GL-(11 TO 9)
-------------	---------------------------	-------------------------	---

Regd. Office GAT No. 152 Lakmapur Taluka Dindori Nashik 422 202 Maharashtra Tel +91 2557 250375/462

Fax +91 2557250376

Corporate Identity Number: L74999MH1934PLC002093

BUILDING SOLUTIONS | ROOFING | WALLS | CEILINGS | CLADDING | STEEL BUILDINGS

Building design loads and governing building code is provided by the Customer and is not validated by Everest Industries Limited. The customer is responsible for contacting the local consultant / architect or project Design Professional to obtain all code and loading information for this specific building site.

This certificate qualifies when actual loads on the structure do not exceed the design loads mentioned above under any circumstances, building enclosure does not change due to addition/deletion of openings or any other modifications, no alterations / additions are made to the building without written consent of Everest Industries Limited and building has been maintained as per the building maintenance manual.

This certification DOES NOT apply to the design of the foundation or other on-site structures or components not supplied by Everest Industries Limited, nor does it apply to unauthorised modifications to building components. Furthermore, it is understood that certification is based upon the premise that all components will be erected or constructed in strict compliance with pertinent latest controlled documents of this project. Everest Industries Limited DOES NOT provide general review of erection during or after building construction unless specifically agreed to in the contract documents.

This certification is valid for 20 years. Further extension of stability will be issued for a period of 5 years each time till 50 years with a pre-condition of conducting a joint inspection (from either side) for assessing the building for

- Any physical damage
- Modification carried out on the structure overlooking the design conditions during the period of existence since it is handed over,
- Any deterioration caused in the structure owing to improper maintenance or any Natural calamities.
- modification carried out without our notice of Everest
- Physical Damage to the structure

For Everest Industries Limited



Date: 19th September 2024

General Manager – Engineering and Design

Regd. Office GAT No. 152 Lakhmapur Taluka Dindori Nashik 422 202 Maharashtra Tel +91 2557 250375/462

Fax +91 2557250376

Corporate Identity Number: L74999MH1934PLC002093

BUILDING SOLUTIONS | ROOFING | WALLS | CEILINGS | CLADDING | STEEL BUILDINGS

Letter of Certification – Design & Stability

Everest Reference/Job No.: PB-02426- A2

Customer: M/s. Pragati Infra solution pvt ltd
Address: 31-P, Sector 38, Gurugram, Haryana -
122003

This is to certify that the strengthening of mezzanine floor is done between GL-9-10 (A to B) and GL-9-10 (S to T).
Mezzanine is safe in strength and serviceability for the below loading.

Mezzanine Dead and Collateral Loads

- Floor dead load: 4.125 KN/sqm
- Additional dead load: 3.75 KN/sqm (Middle portion of strengthening portion)
- Additional dead load: 2.50 KN/sqm (Adjacent portion of strengthening portion)

Mezzanine live Load

Mezzanine live Load: 4.50 KN/Sq.m.



For Everest Industries Limited



Date: 20th September 2024
General Manager – Engineering and Design

Regd. Office GAT No. 152 Lakhmapur Taluka Dindori Nashik 422 202 Maharashtra Tel +91 2557
250375/482

Fax +91 2557250376

Corporate Identity Number: I 74999MH1834P (C002093)

BUILDING SOLUTIONS | ROOFING | WALLS | CEILINGS | CLADDING | STRUCTURAL BUILDINGS

Annexure VI
Forest NOC



प्रभागीय वन अधिकारी द्वारा स्पष्टीकरण पत्र
Clarification letter by
Concerned Divisional Forest Officer
हरियाणा सरकार / Government of Haryana



गैर-वन भूमि पर वन कानून उपयुक्तता के विषय में स्पष्टीकरण पत्र।
Clarification letter regarding applicability of forest laws on non forest land.

नाम Name	आदानी लॉजिस्टिक्स लिमिटेड Adani Logistics Limited
संगठन का नाम Organisation Name	Adani Logistics Limited
वर्तमान पता Current Address	Ferozepur, Palwal, Haryana
भूमि स्थान Land Location	Ferozepur, Palwal, Village -firozpur, Tehsil & Dist. Palwal
भूमि मापन Land Measurements	66.275 (Acre)
आयत नम्बर / मुरबा नम्बर Rectangle No./ Murba No.	50, 58, 61, 62, 63, 70, 71, 72

Reference No. (SRN):- TNT-4TK-VB12

जारी करने की तिथि / Date of Issuance: 28-01-2022

जारी करने का स्थान / Place of Issuance: Palwal

जारी करने वाला प्राधिकरण / Issuing Authority: Divisional Forest Officer



This is a Digitally Signed Certificate and does not require physical signature. The authenticity of this certificate can be verified from the verification link mentioned below:

<https://164.100.137.243/eservices/mobileapi/verify/clarification/TNT4TKVB12>



प्रभागीय वन अधिकारी द्वारा स्पष्टीकरण पत्र
Clarification letter by
Concerned Divisional Forest Officer
हरियाणा सरकार / Government of Haryana



गैर-वन भूमि पर वन कानून उपयुक्तता के विषय में स्पष्टीकरण पत्र।

Clarification letter regarding applicability of forest laws on non forest land.

किला नम्बर Killa Number	50//4/1, 6/2/2, 7/2, 8, 12/2, 13, 14, 15/1/1, 16/2/1, 17, 18, 19/1, 19/2, 22/1, 22/2, 23/1, 23/2, 24/1, 24/2, 25/1/1, 25/1/1/2, 25/1/2/1, 58//1/1, 4/3, 5/1/1, 5/1/2, 6/2/1, 6/2/2, 7/1, 7/2, 8/1, 8/2, 9/1, 9/2, 10, 11/1, 12/1, 12/2, 13/1, 13/2, 13/3, 13/4, 14, 15/1, 16/2, 17/1, 17/2, 18, 19/1, 21, 22/1, 22/2, 23/1/1, 23/1/2, 23/2, 24/1, 24/2, 25/1, 25/2/1, 26, 61//6/2, 14, 15/1, 15/2, 15/3, 16, 17, 24/1, 24/2, 25, 62//1, 2, 3, 4, 5, 6, 7, 8/1, 8/2, 9, 10/1/1, 10/2, 11, 12/1, 12/2, 13/1, 13/2, 14, 15, 16, 17, 18/1, 18/2, 19/1/1, 19/2, 20/1, 20/2, 21, 22/1, 22/2, 23/1, 23/2, 24/1, 24/2, 24/3, 25, 63//10/2, 11/1, 20/2, 21, 70//1, 10/1, 10/2/1, 71//1, 3/1, 3/2, 3/3, 4/1, 4/2, 5, 6/1, 6/2, 7/1, 72//5/1
प्रयोजन Purpose	Warehouse



जारी करने की तिथि / Date of Issuance: 28-01-2022

जारी करने का स्थान / Place of Issuance: Palwal

जारी करने वाला प्राधिकरण / Issuing Authority: Divisional Forest Officer

This is a Digitally Signed Certificate and does not require physical signature. The authenticity of this certificate can be verified from the verification link mentioned below:

<https://164.100.137.243/eservices/mobileapi/verify/clarification/TNT4TKVB12>



प्रभागीय वन अधिकारी द्वारा स्पष्टीकरण पत्र
Clarification letter by
Concerned Divisional Forest Officer
हरियाणा सरकार / Government of Haryana



गैर-वन भूमि पर वन कानून उपयुक्तता के विषय में स्पष्टीकरण पत्र।

Clarification letter regarding applicability of forest laws on non forest land.

Applicant Adani Logistics Limited located at village /city Ferozepur district Palwal
made a proposal to use this land for Warehouse. It is made clear that:

a) As per records available above said land is not part of notified Reserved Forest, Protected Forest under Indian Forest Act, 1927 or any area closed under section 4 of Punjab Land Preservation Act, 1900.

b) It is clarified that by the Notification No. S.O.8/PA.2/1900/S.4/2013 dated 4th January, 2013, all Revenue Estate of Palwal is notified u/s 4 of PLPA 1900 and S.O.81/PA.2/1900/S.3/2012 u/s 3 of PLPA 1900. The area is however not recorded as forest in the Government record but felling of any tree is strictly prohibited without the permission of Divisional Forest Officer, Palwal.

c) If approach is required from Protected Forest by the user agency, the clearance/ regularization under Forest Conservation Act 1980 will be required. Without prior clearance from Forest Department, the use of Forest land for approach road is strictly prohibited. M/s Adani Logistics Limited whose land is located at village/city, Ferozepur District Palwal must obtain clearance as applicable under Forest Conservation Act 1980.

d) As per the records available with the Forest Department, Palwal the area does not fall in areas where plantations were raised by the Forest Department under Aravalli project.

e) All other statutory clearances mandated under the Environment Protection Act. 1986, as per the notification of Ministry of Environment and Forests, Government of India, dated 07-05-1992 or any other Act/ order shall be obtained as applicable by the project proponents from the concerned authorities.

f) The project proponent will not violate any Judicial Order/ direction issued by the Hon'ble Supreme Court/ High Courts.

g) It is clarified that the Hon'ble Supreme Court has issued various judgments dated 07.05.2002, 29.10.2002, 16.12.2002, 18.03.2004, 14.05.2008 etc. pertaining to Aravalli region in Haryana, which should be complied with.

h) It shall be the responsibility of user agency/ applicant to get necessary clearances/ permissions under various Acts and Rules applicable if any, from the respective authorities/ Department.

i) This certificate is not applicable in case of Environment Department notification dated 10.03.2016 for Screening Plant, and notification dated 11.05.2016 for Stone Crusher. Investor/Applicant has to take clearance from Environment Department in case of Screening Plant and Stone Crusher.

It is subject to the following conditions:

1. Clarification Issued To Fulfill Above Conditions. Fac 1980
Not Applicable.



Date: 28-01-2022

Place: Palwal

Deepak Patil

(Divisional Forest Officer)

This is a Digitally Signed Certificate and does not require physical signature. The authenticity of this certificate can be verified from the verification link mentioned below:

<https://164.100.137.243/eservices/mobileapi/verify/clarification/TNT4TKVB12>

Annexure VII
CTE & CTO from HSPCB



HARYANA STATE POLLUTION CONTROL BOARD



**Regional office Palwal, 2nd Floor, HSVP Office
Complex, Near Gymkhana Club Sector 12, Palwal-
121102. Email:- hspcbropal@gmail.com**

Website: www.hrocmmms.nic.in E-Mail - hspcbho@gmail.com

Telephone No.: 0172-2577870-73

No. HSPCB/Consent/ : 313116324PALCTE56633400

Dated:22/03/2024

To.

**M/s : M/s Blue Star Realtors Limited
Blue star realtors ltd village , firojpur, tahsel palwal, haryana 121102
PALWAL
121102**

Sub. : Grant of consent to Establish to M/s M/s Blue Star Realtors Limited

Please refer to your application no. 56633400 received on dated 2024-03-02 in regional office Palwal.

With reference to your above application for consent to establish, M/s M/s Blue Star Realtors Limited is hereby granted consent as per following specification/Terms and conditions.

Consent Under	AIR/WATER
Period of consent	22/03/2024 - 21/03/2029
Industry Type	Building and construction projects having quantity of waste water generation 10 KLD to 100 KLD irrespective of their built-up area
Category	ORANGE
Investment(In Lakh)	11617.68
Total Land Area (Sq. meter)	109974.0
Total Builtup Area (Sq. meter)	42378.0
Quantity of effluent	
1. Trade	0.0 KL/Day
2. Domestic	20.0 KL/Day
Number of outlets	1.0
Mode of discharge	
1. Domestic	STP
2. Trade	0
Permissible Domestic Effluent Parameters	
1. BOD	10 mg/l
2. COD	50 mg/l
3. TSS	20 mg/l
Permissible Trade Effluent Parameters	
1. NA	mg/l

Number of stacks	1
Height of stack	
1. Stack attached with 125 KVA DG set	4.24 metre
Permissible Emission parameters	
1. NA	
Capacity of boiler	
1. NA	Ton/hr
Type of Furnace	
1. NA	
Type of Fuel	
1. Diesel	0.181 KL/day

Regional Officer, Palwal
Haryana State Pollution Control Board.

Terms and conditions

1. The industry has declared that the quantity of effluent shall be 20 KL/Day i.e 0KL/Day for Trade Effluent, 0 KL/Day for Cooling, 20 KL/Day for Domestic and the same should not exceed .
2. The above 'Consent to Establish' is valid for 60 months from the date of its issue to be extended for another one year at the discretion of the Board or till the time the unit starts its trial production whichever is earlier. The unit will have to set up the plant and obtain consent during this period.
3. The officer/official of the Board shall have the right to access and inspection of the industry in connection with the various processes and the treatment facilities being provided simultaneously with the construction of building/machinery. The effluent should conform the effluent standards as applicable
4. That necessary arrangement shall be made by the industry for the control of Air Pollution before commissioning the plant. The emitted pollutants will meet the emission and other standards as laid/will be prescribed by the Board from time to time.
5. The applicant will obtain consent under section 25/26 of the Water (Prevention & Control of Pollution) Act, 1974 and under section 21/22 of the Air (Prevention & Control of Pollution) Act,1981 as amended to-date-even before starting trial production
6. The above Consent to Establish is further subject to the conditions that the unit complies with all the laws/rules/decisions and competent directions of the Board/Government and its functionaries in all respects before commissioning of the operation and during its actual working strictly.
7. No in-process or post-process objectionable emission or the effluent will be allowed, if the scheme furnished by the unit turns out to be defective in any actual experience
8. The Electricity Department will give only temporary connection and permanent connection to the unit will be given after verifying the consent granted by the Board, both under Water Act and Air Act.
9. Unit will raise the stack height of DG Set/Boiler as per Board's norms.
10. Unit will maintain proper logbook of Water meter/sub meter before/after commissioning.

11. That in the case of an industry or any other process the activity is located in an area approved and that in case the activity is sited in an residential or institutional or commercial or agricultural area, the necessary permission for siting such industry and process in an residential or institutional or commercial or agricultural area or controlled area under Town and Country Planning laws CLU or Municipal laws has to be obtained from the competent Authority in law permitting this deviation and be submitted in original with the request for consent to operate.
12. That there is no discharge directly or indirectly from the unit or the process into any interstate river or Yamuna River or River Ghaggar.
13. That the industry or the unit concerned is not sited within any prohibited distances according to the Environmental Laws and Rules, Notification, Orders and Policies of Central Pollution control Board and Haryana State Pollution Control Board.
14. That of the unit is discharging its sewage or trade effluent into the public sewer meant to receive trade effluent from industries etc. then the permission of the Competent Authority owing and operating such public sewer giving permission letter to his unit shall be submitted at time of consent to operate.
15. That if at any time, there is adverse report from any adjoining neighbor or any other aggrieved party or Municipal Committee or Zila Parishad or any other public body against the unit's pollution; the Consent to Establish so granted shall be revoked.
16. That all the financial dues required under the rules and policies of the Board have been deposited in full by the unit for this Consent to Establish.
17. In case of change of name from previous Consent to Establish granted, fresh Consent to Establish fee shall be levied.
18. Industry should adopt water conservation measures to ensure minimum consumption of water in their Process. Ground water based proposals of new industries should get clearance from Central Ground Water Authority for scientific development of previous resource.
19. That the unit will take all other clearances from concerned agencies, whenever required.
20. That the unit will not change its process without the prior permission of the Board.
21. That the Consent to Establish so granted will be invalid, if the unit falls in Aravali Area or non conforming area.
22. That the unit will comply with the Hazardous Waste Management Rules and will also make the non-leachate pit for storage of Hazardous waste and will undertake not to dispose off the same except for pit in their own premises or with the authorized disposal authority.
23. That the unit will submit an undertaking that it will comply with all the specific and general conditions as imposed in the above Consent to Establish within 30 days failing which Consent to Establish will be revoked.
24. That unit will obtain EIA from MoEF, if required at any stage.
25. In case of unit does not comply with the above conditions within the stipulated period, Consent to Establish will be revoked.
26. That unit will obtain consent to operate from the board before the start of product activity.

Specific Conditions

Other Conditions :

1. The applicants shall maintain good house keeping both within the premises. All hose pipelines valves, storage tanks etc. shall be leak proof. In plant allowable pollutants levels, if specified by State Board should be met strictly. 2. The applicant/company shall comply with and carry out directive/orders issued by the Board in this consent order at all subsequent times without negligence of his /its part. The applicant/company shall be liable for such legal action against him as per provision of the law/act in case of violation of any order/directives. Issued at any time and or non compliance of the terms and conditions of his consent order. 3. The applicant shall make an application for grant of consent at least 90 days before the date of expiry of this consent. 4. Necessary fee as prescribed for obtaining renewal consent shall be paid by the applicant along with the consent application. 5. If due to any technological improvement or otherwise this Board is of opinion that all or any of the conditions referred to above required variation (including the change of any control equipment either in whole or in part) this Board shall after giving the applicant an opportunity of being heard vary all or such condition and there upon the applicant shall be bound to comply with the conditions so varied. 6. The industry shall provide adequate arrangement for fighting the accidental leakages, discharge of any pollutants gas/liquids from the vessels, mechanical equipment etc. which are likely to cause environment pollution. 7. The industry shall comply noise pollution (Regulation and control) Rules, 2000. 8. The industry shall comply all the direction/Rules/Instructions as may be issued by the MOEF/CPCB/HSPCB from time to time. 9. The industry shall ensure that various characteristics of the effluents remain within the tolerance limits as specified in EPA Standard and as amended from time to time and at no time the concentration of any characteristics should exceed these limits for discharge. 10. The industry would immediately submit the revised application to the Board in the event of any change in the raw material in process, mode of treatment/discharge of effluent. In case of change of process at any stage during the consent period, the industry shall submit fresh consent application along with the consent to operate fee, if found due, which may be on any account and that shall be paid by the industry and the industry would immediately submit the consent application to the Board in the event of any change during the year in the raw material, quantity, quality of the effluent, mode of discharge, treatment facilities etc. 11. The officer/official of the Board shall reserve the right to access for the inspection of the industry in connection with the various process and the treatment facilities. The consent to operate is subject to review by the Board at any time. 12. Permissible limits for any pollutants mentioned in the consent to operate order should not exceed the concentration permitted in the effluent by the Board. 13. The industry shall pay the balance fee, in case it is found due from the industry at any time later on. 14. If the industry fails to adhere to any of the conditions of this consent to operate order, the consent to operate so granted shall automatically lapse. 15. If the industry is closed temporarily at its own, they shall inform the Board and obtain permission before restart of the unit. 16. The industry shall comply all the Directions/ Rules/Instructions issued from time to time by the Board. 17. That the unit would not change the process or start any new process without prior intimation to the board. 18. That the unit will adopt cleaner technology thereby reducing pollution load. 19. That the unit will provide inter locking arrangement of DG set and will install RECD and dual fuel system in compliance of directions issued by CAQM 20. That the unit will comply with all the provisions of Hazardous Waste Rules and submit return under HWM Rules on yearly basis 21. The above 'Consent to Establish' is valid for 60 months from the date of its issue to be extended for another one year at the discretion of the Board or till the time the unit starts its trial production whichever is earlier. The unit will have to set up the plant and obtain consent during this period. 22. That necessary arrangement shall be made by the industry for the control of Air Pollution before commissioning the plant. The emitted pollutants will meet the emission and other standards as laid/will be prescribed by the Board from time to time. 23. The applicant will obtain consent under section 25/26 of the Water (Prevention & Control of Pollution) Act, 1974 and under section 21/22 of the Air (Prevention & Control of Pollution) Act, 1981 as amended to-date-even before starting trial production 24. The above Consent to Establish is further subject to the conditions that the unit complies with all the laws/rules/decisions and competent directions of the Board/Government and its functionaries in all respects before commissioning of the operation and during its actual working strictly. 25. No in-process or post-process objectionable emission or the effluent will be allowed, if the scheme furnished by the unit turns out to be defective in any actual experience 26. The Electricity Department will give only temporary connection and permanent connection to the unit will be given after verifying the consent granted by the Board, both under Water Act and Air Act. 27. Unit will raise the stack height of DG Set/Boiler as per Board's norms. 28. Unit will maintain proper logbook of Water meter/sub meter before/after commissioning. 29. That in the case of an industry or any other process the activity is located in an area approved and that in case the activity is sited in an residential or institutional or commercial or agricultural area, the necessary permission for siting such industry and process in an residential or institutional or commercial or agricultural area or controlled area under Town and Country Planning laws CLU or Municipal laws has to be obtained from the competent Authority in law permitting this deviation and be submitted in original with the request for consent to operate. 30. That there is

no discharge directly or indirectly from the unit or the process into any interstate river or Yamuna River or River Ghaggar. 31. That the industry or the unit concerned is not sited within any prohibited distances according to the Environmental Laws and Rules, Notification, Orders and Policies of Central Pollution control Board and Haryana State Pollution Control Board. 32. That if at any time, there is adverse report from any adjoining neighbor or any other aggrieved party or Municipal Committee or Zila Parishad or any other public body against the unit's pollution; the Consent to Establish so granted shall be revoked. 33. That all the financial dues required under the rules and policies of the Board have been deposited in full by the unit for this Consent to Establish. 34. In case of change of name from previous Consent to Establish granted, fresh Consent to Establish fee shall be levied. 35. Industry should adopt water conservation measures to ensure minimum consumption of water in their Process. Ground water based proposals of new industries should get clearance from Central Ground Water Authority for scientific development of previous resource. 36. That the unit will take all other clearances from concerned agencies, whenever required. 37. That the unit will not change its process without the prior permission of the Board. 38. That the Consent to Establish so granted will be invalid, if the unit falls in Aravali Area or non conforming area. 39. That the unit will comply with the Hazardous Waste Management Rules and will also make the non-leachate pit for storage of Hazardous waste and will undertake not to dispose off the same except for pit in their own premises or with the authorized disposal authority. 40. That the unit will submit an undertaking that it will comply with all the specific and general conditions as imposed in the above Consent to Establish within 30 days failing which Consent to Establish will be revoked. 41. That unit will obtain EIA from MoEF, if required at any stage. 42. In case of unit does not comply with the above conditions within the stipulated period, Consent to Establish will be revoked. 43. That unit will obtain consent to operate from the board before the start of product activity 44. The unit will comply with all the directions issued by MoEF for infrastructure development projects. 45. The unit has to register on Dust Portal App of CPCB/HSPCB and has to comply with all the norms. 46. The unit will comply with all the provisions of permission obtained from Town & Country Planning Department.

HARYANA STATE

Regional Officer, Palwal

Haryana State Pollution Control Board.





HARYANA STATE POLLUTION CONTROL BOARD

Regional office Palwal, 2nd Floor, HSVP Office Complex, Near Gymkhana Club Sector 12, Palwal-121102. Email:- hspcbropal@gmail.com
E-mail: hspcb@hry.nic.in



No. HSPCB/Consent/ : 313116325PALCTO82597692

Dated:01/01/2025

To.

M/s :M/s Blue Star Realtors Limited
Blue star realtors ltd village , firojpur, tahsel palwal, haryana 121102

Subject: Grant of consent to operate to M/s M/s Blue Star Realtors Limited.

Please refer to your application no. 82597692 received on dated 2024-12-17 in regional office Palwal. With reference to your above application for consent to operate, M/s M/s Blue Star Realtors Limited is here by granted consent as per following specification/Terms and conditions.

Consent Under	BOTH
Period of consent	01/01/2025 - 31/12/2030
Industry Type	Building and construction projects having quantity of waste water generation 10 KLD to 100 KLD irrespective of their built-up area
Category	ORANGE
Investment(In Lakh)	11844.07
Total Land Area(Sq. meter)	109974.0
Total Builtup Area(Sq. meter)	42378.0
Quantity of effluent	
1. Trade	0.0 KL/Day
2. Domestic	20.0 KL/Day
Number of outlets	1.0
Mode of discharge	
1. Domestic	Irrigation and flushing
2. Trade	0
Domestic Effluent Parameters	
1. BOD	10 mg/l
2. TSS	20 mg/l
3. COD	50 mg/l
4. fecal coliform	100
5. pH	5.5.9.0
Trade Effluent Parameters	
1. BOD	0 mg/l
Number of stacks	1
Height of stack	

1. stack to DG	4.24 meter
Emission parameters	
1. NA	
Product Details	
1. NA	0 Metric Tonnes/day
Capacity of boiler	
1. NA	Ton/hr
Type of Furnace	
1. NA	
Type of Fuel	
1. Diesel	0.181 KL/day
Raw Material Details	
NA	Metric Tonnes/Day

*Regional Officer, Palwal
Haryana State Pollution Control Board.*

Terms and conditions

1. The applicants shall maintain good house keeping both within factory and in the premises. All hose pipelines valves, storage tanks etc. shall be leak proof. In plant allowable pollutants levels, if specified by State Board should be met strictly.
2. The applicant/company shall comply with and carry out directive/orders issued by the Board in this consent order at all subsequent times without negligence of his /its part. The applicant/company shall be liable for such legal action against him as per provision of the law/act in case of violation of any order/directives. Issued at any time and or non compliance of the terms and conditions of his consent order.
3. The applicant shall make an application for grant of consent at least 90 days before the date of expiry of this consent.
4. Necessary fee as prescribed for obtaining renewal consent shall be paid by the applicant alongwith the consent application.
5. If due to any technological improvement or otherwise this Board is of opinion that all or any of the conditions referred to above required variation (including the change of any control equipment either in whole or in part) this Board shall after giving the applicant an opportunity of being heard vary all or such condition and there upon the applicant shall be bound to comply with the conditions so varied.
6. The industry shall provide adequate arrangement for fighting the accidental leakages, discharge of any pollutants gas/liquids from the vessels, mechanical equipment etc. which are likely to cause environment pollution.
7. The industry shall comply noise pollution (Regulation and control) Rules, 2000.
8. The industry shall comply all the direction/Rules/Instructions as may be issued by the MOEF/CPCB/HSPCB from time to time.
9. The industry shall ensure that various characteristics of the effluents remain within the tolerance limits as specified in EPA Standard and as amended from time to time and at no time the concentration of any characteristics should exceed these limits for discharge.

10. The industry would immediately submit the revised application to the Board in the event of any change in the raw material in process, mode of treatment/discharge of effluent. In case of change of process at any stage during the consent period, the industry shall submit fresh consent application alongwith the consent to operate fee, if found due, which may be on any account and that shall be paid by the industry and the industry would immediately submit the consent application to the Board in the event of any change during the year in the raw material, quantity, quality of the effluent, mode of discharge, treatment facilities etc.
11. The officer/official of the Board shall reserve the right to access for the inspection of the industry in connection with the various process and the treatment facilities. The consent to operate is subject to review by the Board at any time.
12. Permissible limits for any pollutants mentioned in the consent to operate order should not exceed the concentration permitted in the effluent by the Board.
13. The industry shall pay the balance fee, in case it is found due from the industry at any time later on.
14. If the industry fails to adhere to any of the conditions of this consent to operate order, the consent to operate so granted shall automatically lapse.
15. If the industry is closed temporarily at its own, they shall inform the Board and obtain permission before restart of the unit.
16. The industry shall comply all the Directions/ Rules/Instructions issued from time to time by the Board.
17. Industry should adopt water conservation measures to ensure minimum consumption of water in their process. Ground water based proposals of new industries should get clearance from Central Ground Water Authority (CGWA)/ Haryana Water Resources (Conservation, Regulation and Management) Authority (HWRA) for scientific development of precious resource.
18. The industrial/non industrial sector projects shall develop green belt (as applicable) in its premises including periphery, entry and exit, as per notifications/conditions of EC/directions of MOEF/CPCB/SPCB/NGT/ any court of law. In case of stone crushers, hot mix plants, mineral grinding units, screening plants and brick kilns etc., the unit shall develop adequate green belt and erect barrier/barricade/boundary wall as applicable, as per notifications/directions of MOEF/CPCB/SPCB/NGT/ any court of law.
19. The unit shall develop paved or hard surfaced approach road to the site of unit (including the storage site, if it is at different place) from the nearest public road for transportation of raw material/final product.

Specific Conditions :

1. CTO so granted will be without prejudice to any violation made by unit in past & will be deemed cancelled if any such violation come to the notice of the Board at any stage and the CTO so granted will not affect the prosecution action to be initiated against the unit for such past violations caused by the unit.
2. Unit will not change the quantity of domestic effluent/trade effluent/ air emissions sources without prior permission of the Board.
3. Unit will obtain all necessary clearance from all concerned departments.
4. The unit will operate its pollution control devices regularly and will maintain proper logbook for the same.
5. Unit will obtain necessary Authorization HWM Rules, 2016& will apply for CTO renewal at least 90 days before expiry date of CTO.
6. Unit will maintain good housekeeping and will comply with the provisions of SWM Rules, 2016.
7. Unit will deposit balance fee/ environmental

compensation applicable on the unit, if any found at any stage pending/applicable against the unit, unit will be liable to pay the same. 8. Unit will comply with all the direction issued time to time by HSPCB, CPCB, CAQM, Hon'ble NGT, Hon'ble Punjab & Haryana High Court, Hon'ble Supreme Court of India and other concerned authorities. 9. Renewal of CTO will not prevent the Board from taking appropriate action against the defaulting units including revoking the CTO, which will fail to comply with any of the conditions of the CTO or any relevant provisions of the Water Act, 1974 and Air Act, 1981. 10. The standards prescribed under environmental laws by MoEF&CC/ CPCB are followed by the Board. Further, it is clarified that the standards to be prescribed from time to time under environmental laws by MoEF&CC/CPCB shall also be deemed to be the standards of Board. Provided that in case any stringent parameters will be prescribed by the Board on any subject where upon parameters are also provided by MoEF&CC/CPCB, the standards prescribed by the Board will be followed. The general standards prescribed under EP Rules, 1986 (as amended) shall be applicable on the industries for which specific standards are not prescribed. 11. Grant or renewal of CTE and CTO does not prevent the Board from revoking of those CTE and CTO including taking appropriate action against those defaulting units, where CTE or CTO has been obtained or got extended on the basis of wrong declaration or false documents and also who fail to comply with any of the conditions of CTE/CTO granted to such units or any relevant provisions of Water Act, 1974 and Air Act, 1981 beside forfeiture of performance security deposited by the unit for obtaining CTE. 12. Unit will provide the stack height of all the sources as per EPA Act, 1986 & will comply with the prescribed standards for discharge of effluent/ air emission as per EPA Act, 1986 & any further amended standards. 13. Unit will submit Annual report of Hazardous waste management Rules and environment statement as per the provision of applicable laws. 14. Unit will not use D.G. sets without converting the D.G. sets to Dual fuel & install retrofit APCD within the prescribed time limit prescribed by CAQM, afterward unit will operate the D.G. sets for the time limits prescribed & will maintain logbook for running hours of D.G. sets as per CAQM directions issued time to time.



*Regional Officer, Palwal
Haryana State Pollution Control Board.*

Annexure VIII
Power Allotment letter



DAKSHIN HARYANA BIJLI VITRAN NIGAM LIMITED

(A Power Distribution & Retail Supply Utility, Govt. of Haryana)
Office of the Superintending Engineer (OP) Circle, DHBVNL, Palwal
Address: - Old Court Complex Opposite Rest House NH-19, Palwal (HR).
Email: - seopalwal@dhbvn.org.in, Telephone No. 01275- 255009
Head Office: - Vidyut Sadan, Vidyut Nagar, Hisar -125005 (HR)
CIN: U99999HR1999SGC034165, Website: www.dhbvn.org.in



To

Executive Engineer/OP
Division, DHBVNL, Palwal

Memo No. 597

Dated 23/01/24

Subject: - Sanction of load of 1000 KW with contract demand of 1000 KVA applied by M/s Blue Star Realtors Pvt. Ltd. at village Firojpur applied vide application no. F42-1023-363 dated 27.10.2023 under HT NDS supply category under (OP) S/U S/Division, DHBVN, Palwal.

Ref: - Technical feasibility report in respect of the above referred application along with the recommendations received from your office vide memo no. 1209 dated 18.01.2024.

The subject cited application has been considered in view of the technical feasibility report made available by you as per provisions of Sales Circular no. D-08/2021.

Accordingly, applied load of 1000 KW with contract demand of 1000 KVA is hereby sanctioned (As per the following details) in exercise of the power conferred upon to this office vide Sales Circular no. D-06/2023 dated 18.01.2023 of the Nigam.

"The applied load of 1000 KW with CD 1000 KVA shall be fed at 11 KV level on proposed 11 KV Independent feeder emanating from power T/F T-1 (66/11 KVA, 25/31.5 MVA) of 66 KV Sub-Stations, Huda Sec-02 (Palwal)."

1. Accordingly, the subject cited application be processed further and the connection be released to the applicant within the stipulated timeframe strictly under the existing instructions and provisions of HERC Regulation 4 of the Electricity Supply Code: - "Procedure for release of new connection and modification in existing in connection" circulated vide sales circular no. D-07/2020 dated 28.03.2020.
2. Various activities involved in giving supply of electricity including processing of applications, issue of demand notice, inspection of CEI and testing of the consumer's installation and release of connection shall be under taken as per procedure specified under Regulation 4 of Electricity Supply Code.
3. While releasing the Electricity Connection/Load/Contract Demand to the applicant, it is also to be ensured that the following statutory requirements are duly complied with in letter & spirit of the instructions of Nigam's (as amended from time to time):-

- I. The applicant has complied with the procedure and conditions as specified in Regulation 4 of Electricity Supply Code.
- II. All the documents required to be submitted by the applicant in support of proof of ownership/legal occupation of the premises, proof of identity and other documents, are complete and duly verified in addition to the verification of the category of connection as per its applicability in view of the schedule of tariff circulated vide sales circular no. D-29/2013 dated 25.06.2013 further to be read in conjunction with Sales Circular no. D-14/2022.
- III. All general and miscellaneous charges payable against the application are fully recorded in accordance with the regulation no. HERC/34/2016/1st amendment/2020 dated 19.03.2020 (Duty to supply electricity on request, power to recover expenditure incurred and power to require security); circulated vide sales circular no. D12/2020 dated 25.06.2020.
- IV. All the provisions as contained in the HERC regulation no. HERC/29/2014/2nd amendment dated 08.01.2020 (Duty to supply code 2014; circulated vide sales circular no. D7/2020 dated 28.03.2020, are fully complied with strictly adhered to.
- V. Assessment of the Technical Feasibility report, recommendations for the supply source and supply level and planning for the distribution infrastructure is in strict adherence to the notifications of HERC regulations 3.1 & 3.2 of the Electricity Supply Code
- VI. Development of electrical infra is as per technical service estimate to be prepared in line with the planning & design and technical specifications and construction standards of the Nigam.
- VII. Before commencement of the work/activities, the estimate is duly signed, approved and sanctioned by the competent authorities of the Nigam.
- VIII. The service connection charges or actual expenditure to recover such expenses are completed and got deposited from the applicant in accordance with HERC regulation no. 4 power to recover expenditure—Duty to supply circulated vide Sales Circular no. D-12/2020 dated 25.06.2020.
- IX. In case of the development of the electrical infrastructure requiring any specific clearances and approvals from local bodies, forest department or any other Govt. dept., the same shall be the responsibility of the applicant and in this regard all incidental charges shall be borne by the applicant.
- X. In case of the applicant opting for the creation of the electrical infrastructure at its own as per the planning, design and technical specifications of Nigam, the same may be got carried out through a licensed electrical contractor under regulation 3.10 of Duty to supply regulations. However, inspection for the quality check of the major items is got carried out from Nigam's authorities person before erection of major items besides the quality check of the electrical infrastructure works from time to time. In such instances the supervision charges (as applicable under regulation 3.10 of

duty to supply regulations) are also paid by the applicant as the case may be.

- XI. The applicant as well as the premise where the load is to be released is not a defaulter of any kind whether disputed or undisputed.
 - XII. Seniority for release of connection is maintained in view of the provisions contained in SMI 1.24 and a provision of SMI 4.2 is adhered to in respect of the site for installation of energy meter. These requirements are also to be read in conjunction with the similar requirement stipulated under HERC electricity supply code regulations no. 29/2014 & amendment thereof circulated vide sales circular no. D07/2020 dated 28.03.2020.
 - XIII. Along with the release of connection, under HT supply category, with installation of a suitable energy meter, system of AMR is installed by M&P wing of DHBVNL and its connectivity is established with the Head End System deployed at Data Center Hisar.
 - XIV. Upon creation of new electricity assets and release of connection, system of GIS is also duly got updated w.r.t the asset mapping and consumer indexing.
 - XV. With regards to the installation of Solar Photovoltaic Power Plant, the notification no. 22/52/2005-5 power dated 21.03.2016 of Haryana Renewal Energy Department, circulated by Nigam vide Sales Circular no. D/42/2016 dated 30.12.2016 along with its amendment vide Sales Circular no. D10/2017 dated 16.02.2020, is adhered to by the applicant.
 - XVI. Applicability of any other fundamental instructions & regulations of the Nigam not specified above but otherwise deemed mandatory for the instant case.
4. This sanction of load shall be contingent upon the compliances of the statutory requirements from the applicant as per the instructions/regulations if Nigam stipulated above. However, it is also being made clear that sanction of load of 1000 KW with Contract Demand 1000 KVA has been approved as per the applicable regulations and instructions of the Nigam in view of the A&A form and other documents & details of **M/s Blue Star Realtors Pvt. Ltd. at village Firojpur**. For any misrepresentation of the information & facts and non compliance, this approval shall be void ab-initio. If any of the information & fact found/noticed to be fabricated and misled at any stage, which may otherwise lead to explicit or implicit loss of Nigam, **M/s Blue Star Realtors Pvt. Ltd. at village Firojpur**, shall be liable to make good such loss to Nigam. This shall however be without prejudice to the right of Nigam to take further recourse in the matter as per the legal remedies available with the Nigam.

SE (OP) Circle,
DHBVNL, Palwal

Annexure IX
Fire NOC

From Director General
Fire Service, Haryana Panchkula

To **M/s** Part Adani Logistics Limited
VILLAGE FIROZPUR TEHSIL AND DISTRICT PALWAL
Memo No. FS/2024/761 dated : 08/07/2024

Subject : **Fire Safety Certificate Under 15 mtrs. from the fire safety point of view for Group H- Storage Building at VILLAGE FIROZPUR TEHSIL AND DISTRICT PALWAL of Part Adani Logistics Limited**
:

Reference your letter no. 211162423000130 dated 18/06/2024 on the subject cited above.

Tower Name	Floor Detail	Height	Ground Coverage
WAREHOUSE A1	G+Mezzanine	14.10 mtr.	5672.242 Sqm
WAREHOUSE A2	G+Mezzanine	14.10 mtr.	11580.359 Sqm
WAREHOUSE A3	G+Mezzanine	14.10 mtr.	3926.906 Sqm
WAREHOUSE C	G+Mezzanine	14.10 mtr.	5736.38 Sqm
WAREHOUSE D	G+Mezzanine	14.10 mtr.	15051 Sqm
DRIVER ROOM 01	GROUND FLOOR	3.450 mtr.	382.280 Sqm
DRIVER ROOM 02	GROUND FLOOR	3.450 mtr.	72 Sqm
SECURITY OFFICE	GROUND FLOOR	3.450 mtr.	37.091 Sqm
METER ROOM	GROUND FLOOR	4.0 mtr.	12.387 Sqm
PUMP ROOM	GROUND FLOOR	5.5 mtr.	287.441 Sqm
LT ROOM	GROUND FLOOR	3.9 mtr.	54.240 Sqm
Basement Level	Basement Area	Basement Remarks	
NIL	NIL	OK	

- 1) All the fire fighting equipments shall be maintained in perfect working condition all the time and any lapse rendering non-functional of fire safety measures, management shall be responsible.
- 2) The open set back area is not checked at our end as it shall be checked by concerned building authority/department.
- 3) If any lapse or non functioning of fire system will be the sole responsibility of the owner/occupier.
- 4) All the means of escape shall be kept free of all the type of obstruction all the time.
- 5) All the employees shall be acquainted with the use and maintenance of all fire equipments and method of smooth and speedy safe evacuation of occupants in case of emergency.
- 6) Fire Safety Certificate granted subject to condition that there is no violation in sanctioned building plan by virtue of which fire fighting scheme was approved.
- 7) This Fire Safety Certificate can not be treated in any case for regularizations of unauthorized construction unauthorized use of land if any.
- 8) The owner/occupier shall strictly follow the other applicable rules/by laws laid down regarding fire safety system. If you fail to comply with any of the above terms & conditions, This fire NOC will be deemed cancelled and you will be liable to be punish as per Section 30,31 & 47 of Fire & Emergency Services Act- 2022.
- 9) If the Infringements of Byelaws remains un- noticed the Authority reserves the right to amend the Fire Safety Certificate as and when any such Infringements comes to notice after giving an opportunity of being heard and the Authority shall stand Indemnified against any claim on this account.
- 10) The owner or occupier of the building shall give a self-declaration certificate annually to the effect that the fire fighting system installed in his building is working in good condition and there is no addition/alteration in the building. The Fire Officer may randomly check such building. In case there is any addition/alteration beyond permissible limits under the Haryana Building Code, 2017, the fire safety certificate shall cease to exist and the owner shall apply for approval of revised Fire Fighting Scheme as per the provisions of section 18.

The above Fire Safety Certificate is valid for only **Three** year from the date of issue of this letter Applying renewal of the same well in time shall be the responsibility of owner/occupier.

Remarks:- Part Fire Safety Certificate and in continuation to this office Memo No FS 2024 754 dated 06 07 2024



Deputy Director (Technical)-I,
for Director General, Fire
Service, Haryana

Panchkula

Exercising the power of Director, Fire Services, Haryana

Annexure X
News Paper Advertisement

Date: 25.06.2022

To

The District Town Planner
Department of T&C Planning,
Sector-12, Hathin Road,
Palwal, Haryana.

Sir

Sub:- Adani Logistics Limited - Grant of Environmental Clearance (EC) for Industrial/Warehouse/Logistics Project located at Village- Firozpur, Tehsil & District- Palwal, Haryana under EIA Notification, 2006 - Copy furnished for displaying in the Notice Board - Reg.

Ref:- EC No. EC22A038HR110364 (File No. 21-15/2022-IA-III), dated 17/06/2022 of MoEF&CC, New Delhi.

We wish to inform you that MoEF&CC, New Delhi has granted Environmental Clearance (EC) to Adani Logistics Limited for Industrial/Warehouse/Logistics under EIA Notification, 2006.

In this regard, in compliance with the EC Miscellaneous Condition 2, the copy of the EC is herewith furnished to your good office and request you to display the same in the office Notice Board.

Thanking you.

Yours sincerely,

For Adani Logistics Limited

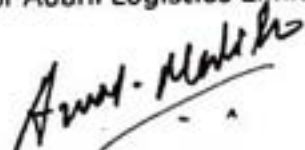
Authorized Signatory

Encl: a/a

Mahender Sharma
5-7-22

Received by :-
O/o District Town Planner
PALWAL

Adani Logistics Ltd
"Adani Corporate House", Shantigram
Near Vaishno Devi Circle, S. G. Highway,
Khodiyar, Ahmedabad 382421,
Gujarat, India
CIN: U63090GJ2005PLC046419

Tel +91 79 2555 5801
Fax +91 79 2555 6490
info@adani.com
www.adani.com

adani

Ports and
Logistics

Date: 25.06.2022

To

The Add. Deputy Commissioner Palwal
Municipal Council
Near Bal Bhawan, Palwal, Haryana.

Sir

Sub:- Adani Logistics Limited – Grant of Environmental Clearance (EC) for Industrial/Warehouse/Logistics Project located at Village- Firozpur, Tehsil & District- Palwal, Haryana under EIA Notification, 2006 – Copy furnished for displaying in the Notice Board – Reg.

Ref:- EC No. EC22A038HR110364 (File No. 21-15/2022-IA-III), dated 17/06/2022 of MoEF&CC, New Delhi.

We wish to inform you that MoEF&CC, New Delhi has granted Environmental Clearance (EC) to Adani Logistics Limited for Industrial/Warehouse/Logistics under EIA Notification, 2006.

In this regard, in compliance with the EC Miscellaneous Condition 2, the copy of the EC is herewith furnished to your good office and request you to display the same in the office Notice Board.

Thanking you.

Yours sincerely,

For Adani Logistics Limited

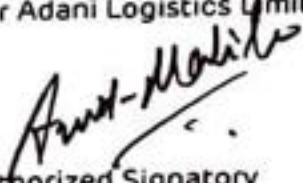
Authorized Signatory

Encl: a/a



Adani Logistics Ltd
"Adani Corporate House", Shantigram
Near Vaishno Devi Circle, S. G. Highway,
Khodiyar, Ahmedabad 382421,
Gujarat, India
CIN: U63090GJ2005PLC046419

Tel +91 79 2555 5801
Fax +91 79 2555 6490
info@adani.com
www.adani.com

ACCUSED-ARRESTED

Stabbing spree at cyber police station, six personnel injured

PHOTO BY AP/WIDEWORLD
A police officer is seen in the foreground, holding a sign that reads "Cyber Police Station" during a demonstration in New Delhi, India, on Jan. 16, 2012. The sign also features a red circle with a white slash through it, a common symbol for prohibition or a ban.



Police officers hold a sign of cyber police station.

PHOTO BY AP/WIDEWORLD
A group of people is seen in the foreground, holding a sign that reads "Cyber Police Station" during a demonstration in New Delhi, India, on Jan. 16, 2012. The sign also features a red circle with a white slash through it, a common symbol for prohibition or a ban.

PHOTO BY AP/WIDEWORLD
A group of people is seen in the foreground, holding a sign that reads "Cyber Police Station" during a demonstration in New Delhi, India, on Jan. 16, 2012. The sign also features a red circle with a white slash through it, a common symbol for prohibition or a ban.

PHOTO BY AP/WIDEWORLD
A group of people is seen in the foreground, holding a sign that reads "Cyber Police Station" during a demonstration in New Delhi, India, on Jan. 16, 2012. The sign also features a red circle with a white slash through it, a common symbol for prohibition or a ban.

PHOTO BY AP/WIDEWORLD
A group of people is seen in the foreground, holding a sign that reads "Cyber Police Station" during a demonstration in New Delhi, India, on Jan. 16, 2012. The sign also features a red circle with a white slash through it, a common symbol for prohibition or a ban.

PHOTO BY AP/WIDEWORLD
A group of people is seen in the foreground, holding a sign that reads "Cyber Police Station" during a demonstration in New Delhi, India, on Jan. 16, 2012. The sign also features a red circle with a white slash through it, a common symbol for prohibition or a ban.

PHOTO BY AP/WIDEWORLD
A group of people is seen in the foreground, holding a sign that reads "Cyber Police Station" during a demonstration in New Delhi, India, on Jan. 16, 2012. The sign also features a red circle with a white slash through it, a common symbol for prohibition or a ban.

Demolition drive at ITO after HC orders

PHOTO BY AP/WIDEWORLD
A demolition drive is underway at the ITO area in New Delhi, India, following a court order. The image shows heavy machinery and workers engaged in the process of demolishing structures.



Demolition drive at ITO area in New Delhi, India, following a court order.

PHOTO BY AP/WIDEWORLD
A demolition drive is underway at the ITO area in New Delhi, India, following a court order. The image shows heavy machinery and workers engaged in the process of demolishing structures.

PHOTO BY AP/WIDEWORLD
A demolition drive is underway at the ITO area in New Delhi, India, following a court order. The image shows heavy machinery and workers engaged in the process of demolishing structures.

PHOTO BY AP/WIDEWORLD
A demolition drive is underway at the ITO area in New Delhi, India, following a court order. The image shows heavy machinery and workers engaged in the process of demolishing structures.

Surprise inspection by Soodia, officials pulled up

PHOTO BY AP/WIDEWORLD
A surprise inspection by Soodia, officials pulled up. The image shows a group of people in a meeting or office setting.

PHOTO BY AP/WIDEWORLD
A surprise inspection by Soodia, officials pulled up. The image shows a group of people in a meeting or office setting.

Over 700 buses in Karhpool Colony to be ready by Sept

PHOTO BY AP/WIDEWORLD
Over 700 buses in Karhpool Colony to be ready by Sept. The image shows a large number of buses parked in a lot.

PHOTO BY AP/WIDEWORLD
Over 700 buses in Karhpool Colony to be ready by Sept. The image shows a large number of buses parked in a lot.

NEW VALUE ADDED TAX (VAT) REGISTRATION

PHOTO BY AP/WIDEWORLD
NEW VALUE ADDED TAX (VAT) REGISTRATION. The image shows a document or form related to VAT registration.

NEW VALUE ADDED TAX (VAT) REGISTRATION

PHOTO BY AP/WIDEWORLD
NEW VALUE ADDED TAX (VAT) REGISTRATION. The image shows a document or form related to VAT registration.

NEW VALUE ADDED TAX (VAT) REGISTRATION

PHOTO BY AP/WIDEWORLD
NEW VALUE ADDED TAX (VAT) REGISTRATION. The image shows a document or form related to VAT registration.

NEW VALUE ADDED TAX (VAT) REGISTRATION

PHOTO BY AP/WIDEWORLD
NEW VALUE ADDED TAX (VAT) REGISTRATION. The image shows a document or form related to VAT registration.

GOVERNMENT OF NCT OF DELHI
Department of Government Public Relations & Publicity
www.nctdelhi.gov.in

Don't miss this chance to avail maximum concession! Bank of India has brought a golden opportunity for 40% discount subject to the one-time settlement scheme offered by Bank of India to avail attractive discount on interest of your 10% account. Start from this golden opportunity to close or settle your 10% account. 40% customers are invited to close their 10% account under one-time settlement scheme and get the benefit of concession by settling the interest at 60% of the total amount of your account (Bank branch on or before 31 June 2012).

GOVERNMENT OF NCT OF DELHI
Department of Government Public Relations & Publicity
www.nctdelhi.gov.in

PUBLIC NOTICE
Interest free on loans for 2.5% with condition.
New Delhi, India, 16th Jan 2012
Department of Government Public Relations & Publicity, New Delhi
Circular No. 1000/2012 dated 16th Jan 2012
Subject: Interest free on loans for 2.5% with condition.
Reference: Public Notice No. 1000/2012 dated 16th Jan 2012.
The Government of NCT of Delhi is pleased to announce that the interest on loans for 2.5% will be waived for the period from 16th Jan 2012 to 31st Dec 2012. The waiver of interest will be subject to the condition that the borrower must have repaid the principal amount of the loan by 31st Dec 2012. The waiver of interest will be subject to the condition that the borrower must have repaid the principal amount of the loan by 31st Dec 2012. The waiver of interest will be subject to the condition that the borrower must have repaid the principal amount of the loan by 31st Dec 2012.

PHOTO BY AP/WIDEWORLD
NEW VALUE ADDED TAX (VAT) REGISTRATION. The image shows a document or form related to VAT registration.

Annexure XI
Details of STP

SEWAGE TREATMENT PLANT FOLLOWED BY ULTRA FILTRATION PLANT

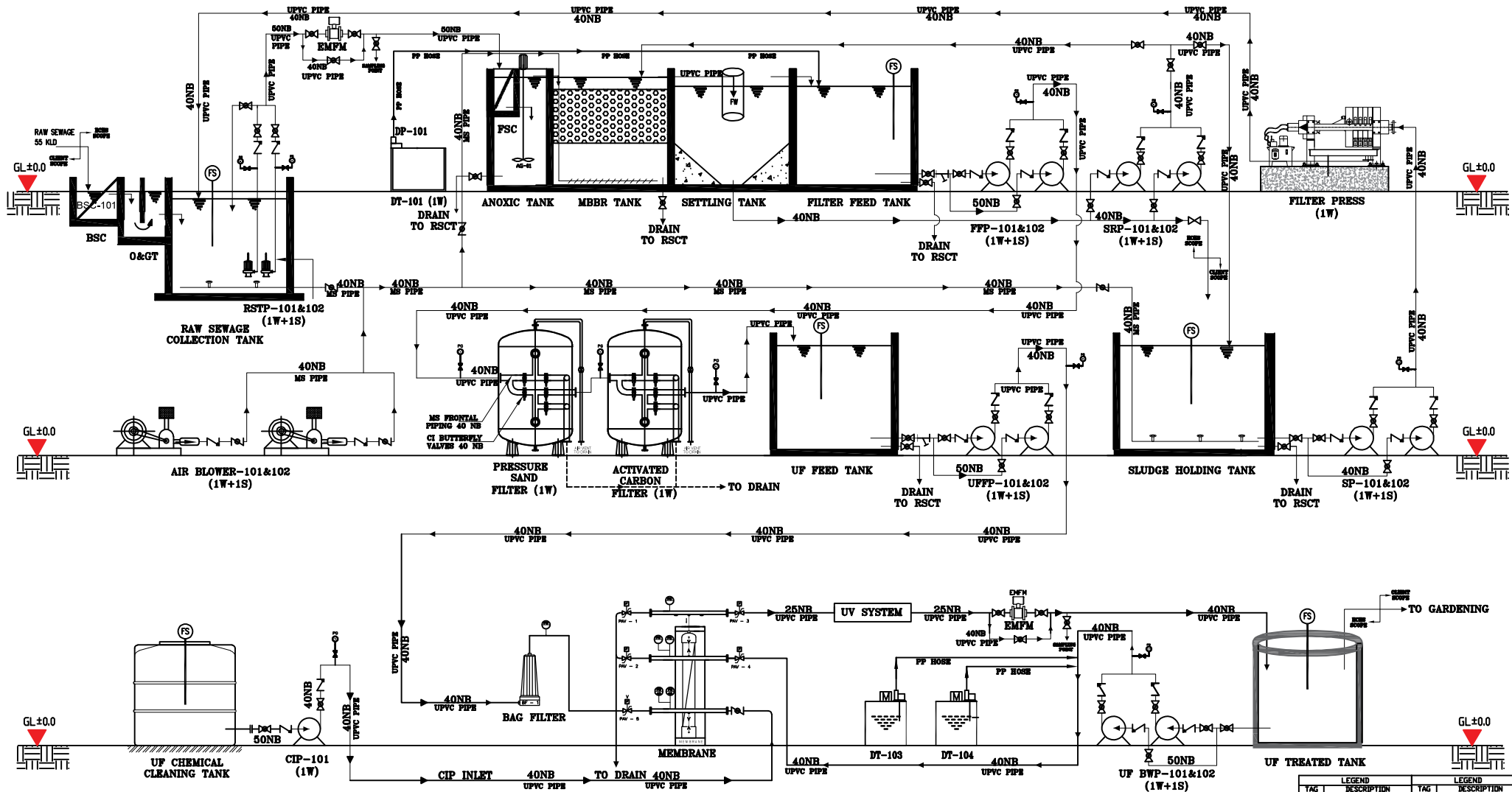

STP - EQUIPMENT				STP - EQUIPMENT			
TAG	QTY.	DESCRIPTION	CAPACITY	TAG	QTY.	DESCRIPTION	CAPACITY
BS-101	1W	BAR SCREEN	-	FP-101	1W	FILTER PRESS	610 x 610mm (8-12 Plates)
RSTP-101&102	1W + 1S	RAW SEWAGE TRANSFER PUMP	2.75 m ³ /hr @ 12m	UFPP-101&102	1W + 1S	UF FEED PUMP	2.75 m ³ /hr @ 30m
SRP-101 &102	1W + 1S	SLUDGE RECIRCULATION PUMP	2.0 m ³ /hr @ 12m	BF-101	1W	BAG FILTER	2.75 m ³ /hr
FFP-101&102	1W + 1S	FILTER FEED PUMP	2.75 m ³ /hr @ 25m	UF-101	1W	UF MEMBRANE & SHED	50 m ²
AB-101 & 102	1W + 1S	AIR BLOWER	100 m ³ /hr @ 0.4kg/cm ²	DP-101	1W	HYPO DOSING TANK	100 LITRES
DT-101	1W	HYPD DOSING TANK	100 LITRES	DP-102	1W	HYPD DOSING TANK	6LPH
DP-101 & 102	1W	HYPD DOSING PUMP	6LPH	DP-103	1W	HYPD DOSING TANK	100 LITRES
PSF-101	1W	PRESSURE SAND FILTER	0.6m Dia x 1.5m HOS	MSEP	DP-103	HYPD DOSING TANK	6LPH
ACF-101	1W	ACTIVATED CARBON FILTER	0.6m Dia x 1.5m HOS	MSEP	DP-101&102	1W + 1S	UF BACK WASH PUMP
SP-101 & 102	1W + 1S	SCREEN PUMP	1.0 m ³ /hr	CI	CI-101	2W	CLEAN IN PLACE PUMP
FSC	1W	FINE SREH	-	SS 304	AGT	1W	AGITATOR WITH MOTOR

STP - LIST OF TANKS		STP - EQUIPMENT					
TAG	DESCRIPTION	MOC	QTY.	DESCRIPTION	CAPACITY/SIZE	MOC	QTY.
BSC	BAR SCREEN CHAMBER	ROC	1 NO	25NB UPVC PIPE	25NB UPVC PIPE	EMFM	1 NO
O>	OIL & GREASE TRAP	ROC	1 NO	40NB UPVC PIPE	40NB UPVC PIPE	EMFM	1 NO
RSCW	RAW SEWAGE COLLECTION WELL	ROC	1 NO	40NB UPVC PIPE	40NB UPVC PIPE	EMFM	1 NO
ANX	ANOXIC TANK	MS FRP	1 NO	40NB UPVC PIPE	40NB UPVC PIPE	EMFM	1 NO
MBBR	MEMBRANE BIOLÓGICAL REACTOR	MS FRP	1 NO	40NB UPVC PIPE	40NB UPVC PIPE	EMFM	1 NO
ST	SETTLING TANK	MS FRP	1 NO	40NB UPVC PIPE	40NB UPVC PIPE	EMFM	1 NO
FFT	FILTER FEED TANK	MS FRP	1 NO	40NB UPVC PIPE	40NB UPVC PIPE	EMFM	1 NO
UFFT	UF FEED TANK	MS FRP	1 NO	40NB UPVC PIPE	40NB UPVC PIPE	EMFM	1 NO
UFFT	UF TREATED TANK	ZINC ALUM	1 NO	40NB UPVC PIPE	40NB UPVC PIPE	EMFM	1 NO
SHT	SLUDGE HOLDING TANK	MS FRP	1 NO	40NB UPVC PIPE	40NB UPVC PIPE	EMFM	1 NO
PS	PLANT SHED	MS	1 NO	40NB UPVC PIPE	40NB UPVC PIPE	EMFM	1 NO
FFS	FILTER PRESS SHED	MS	1 NO	40NB UPVC PIPE	40NB UPVC PIPE	EMFM	1 NO
UFCP	UF CHEMICAL CLEANING TANK	HOPE	1 NO	40NB UPVC PIPE	40NB UPVC PIPE	EMFM	1 NO

LEGEND		LEGEND	
TAG	DESCRIPTION	TAG	DESCRIPTION
○	BALL VALVE	○	FLYAT SWITCH
⊙	PRESSURE GAUGE	⊙	ELECTROMAGNETIC FLOWMETER
⊕	AGITATOR	⊕	PUMP
⊖	Y STRAINER	⊖	MV
⊗	MOTOR	⊗	DOSING PUMP

NAME OF THE PROJECT: SEWAGE TREATMENT PLANT
 CLIENT: MS. BLUE STAR REALTORS PVT.LTD
 MAIN-CONTRACTOR: MS. PRAGATI INFRA SOLUTIONS PVT. LTD.
 PREPARED BY: ECO CARE ENGINEERING SYSTEMS
 NO 10 / 25 EKAMBARAM DABEDAR STREET, ALANDUR, GUNDIRY CHENNAI - 600 016.

DES.	AV	SEN	CHKD.	PP	SEN
DRN.	DR	SEN	APVD.	PP	SEN
TITLE:	PROCESS FLOW DIAGRAM FOR SEWAGE TREATMENT PLANT				SIZE:
DRGNO.	ECES - 413-2023/0224R2				SCALE:
RELEASED FOR:	PRELIMINARY				INFORMATION:
⊙	TENDER	⊙	APPROVAL	⊙	CONSTRUCTION
⊙	AS BUILT				

Annexure XII
HSE Policy

Adani Ports and Special Economic Zone Limited

Occupational Health and Safety Policy

Occupational Health and Safety (OHS) responsibilities are integral in the manner APSEZ does Business at its Ports and Logistics locations.

To provide a Safe and Healthy work environment for our internal and external stakeholders for preventing occupational illness and injury, APSEZ, its subsidiaries and joint ventures, are committed to:

- Provide a safe and healthy work place at all times;
- Ensure compliance in design and operations as per applicable National codes, Standards, Best Practices, Statutory and other stakeholder's requirements;
- Encourage all internal and external stakeholders to follow safe work practices and receive training to improve Health and Safety;
- Every stakeholder has a general responsibility for Safety in their respective operating / project areas;
- Establish OHS committees with the involvement of the management and workers to continually improve the Safety culture;
- Involvement of working people in terms of consultation and participation;
- Identify the risks and formulate mitigation plans to prevent incidents;
- Formulate emergency preparedness plans to manage all identified emergencies;
- Implement and continually improve the OHS Management System; and
- Measure, monitor and review the OHS performance of organization in accordance with this policy on a regular basis.

The policy shall be reviewed annually for its appropriateness and updated as necessary.



Karan Adani

(Chief Executive Officer)

OCCUPATIONAL HEALTH & SAFETY (OH&S) POLICY

We at Adani, firmly believe that Occupational Health & Safety (OH&S) is an integral part of our activities, policies, processes & business operations and are committed to provide safe and healthy workplace across our operating location, to our employees, relevant stakeholders and nearby communities, to achieve our OH&S Vision "To be the Globally admired OH&S Leader in the Infrastructure space".

Adani recognizes that OH&S and the overall wellbeing of its people is vital to its success and growth aspirations. It is our conviction to promote "Culture of Care" so that every activity is performed in a safe manner which facilitates continual growth and sustainability of our businesses. This is envisioned in our business theme "Growth with Goodness".

To meet our commitment, we shall endeavor to;

- Integrate Occupational Health & Safety aspects in every business decision we make and in every activity we perform. Leaders at all levels, demonstrate their personal commitment to OH&S to promote Principle of Prevention of unsafe situations by integrating requirements from design & engineering stage to operation & maintenance.
- Work with the fundamental belief that all injuries and occupational illness can and must be prevented. Working safely is a condition of employment to meet our goal of "Zero Harm".
- Comply and exceed applicable legal and regulatory OH&S requirements and set highest standards for positive safety compliance, wherever we operate.
- Develop skills, knowledge, competence and build capability by engaging employees, business partners and service providers through appropriate education & training to help them work safely. Influence our business partners in enhancing their OH&S standards.
- Ensure safe place to work by identifying, assessing, and reducing risks & vulnerabilities, to as low as reasonably practicable by applying hierarchy of controls for process, machinery, infrastructure and human behavior and prevent any potential emergency situations.
- Conduct regular audits and facilitate assurance of OH&S programs and take timely action on findings, to integrate learnings ensuring continued compliance to safety management system requirements.
- Proactively report all incidents, investigate root causes and ensure lessons learnt are shared and deployed across the Group companies.
- Set OH&S objective and targets, metrics as indicators of excellence, monitor progress and continually improve performance. Provide adequate resources to ensure continual improvement of OH&S management & performance.

We shall communicate this policy to all our employees, business partners and customers to emphasize their responsibilities and accountabilities for safe performance and thereby establish a renewed commitment towards consultative & participative processes.

Any violation or breach of this policy shall be dealt with procedures framed by the Company from time to time. The policy shall be reviewed periodically for its suitability & relevance to our operations and updated as deemed necessary.



Gautam Adani
Chairman – Adani Group

Date: 04th March 2021

Annexure XIII
Rainwater Harvesting Structures



Rainwater Harvesting Structures



हरियाणा सरकार
हरियाणा जल संसाधन प्राधिकरण
Government of Haryana
Haryana Water Resources Authority

PERMISSION CERTIFICATE FOR GROUND WATER EXTRACTION

Project Name:	Blue Star Realtors Limited							
Project Address:	Blue star realtors ltd village, Firojpur, Tehsil Palwal, Haryana 121102							
Village/MC:	Ferozepur	Tehsil:	Palwal					
District:	PALWAL	State:	Haryana					
Pin Code:	--							
Communication Address:	Blue star realtors ltd village, Firojpur, Tehsil Palwal, Haryana 121102							
Address Regional Office:	Rear Building, 3rd Floor, HSVP, Sector-6, Panchkula							
1. NOC No.:	HWRA/NOC/INF/N/2025/432							
2. Application No.:	HWRA/INF/N/2025/790	3. Category:	Infrastructure					
4. Project Status:	New	5. NOC Type:	New					
6. Ground Water Extraction Permitted:								
Ground Water For	m3/day	m3/year	Valid From	Valid Upto				
Fresh Water	65.00	23725.00	26/05/2025	25/05/2026				
Construction Purpose	0.00	0.00	26/05/2025	--				
Dewatering	--	--	26/05/2025	--				
Total	65.00	23725.00	--	--				
7. Details of Ground Water Extraction: Total Existing No.:	0		Total Proposed No.:	1				
	DW	DCB	BW	TW	DW	DCB	BW	TW
Abstraction Structure*	--	--	--	--	--	--	1	--
*DW - Dug Well;DCB - Dug cum Bore Well;BW - Bore Well;TW - Tube Well;DWLR - Digital Water Level Recorder								
8. Quantum of ground water recharge(m3/year)	28717.00							
9. Number of Piezometers (Observation wells) to be constructed/ monitored & Monitoring mechanism	No. of Piezometers			Monitoring Mechanism				
	0			Manual	DWLR	Telemetry		
			0	0	0			

* Terms & conditions are at the back of this page.

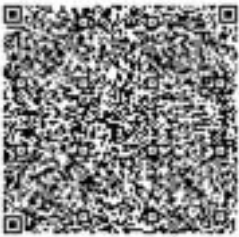

Validity of this NOC shall be subject to compliance of the following mandatory conditions

This NOC for abstraction of ground water, shall be subject to the following terms and conditions

1. NOC is granted to the applicant on the condition that local government water supply agencies are not able to supply the desired quantity of water. In case of supply of water from local agency the applicant shall immediately inform HWRA and reduce the abstraction of ground water accordingly.
2. The applicant abstracting ground water between 100-500 kld shall undertake self-annual water audit and those abstracting ground water more than 500 kld shall undertake water audit through organisations authorised by Government of India or HWRA and submit audit reports at the time of renewal of the NOC.
3. Construction of observation well(s) (piezometer)(s) within the premises and installation of appropriate water level monitoring mechanism shall be mandatory for industries drawing or proposing to draw more than 500kld of ground water and Monitoring of water level shall be done by project applicant. The piezometer (observation well) shall be constructed at a minimum distance of 15 m from the production well. Depth and aquifer zone tapped in the piezometer shall be the same as that of the pumping well wells Detailed guidelines for design and construction of piezometer is given on the portal. Monthly water level data shall be submitted to the HRWA through the web portal on quarterly basis.
4. Injection of treated/untreated wastewater into aquifer system is strictly prohibited.
5. In case of infrastructure projects that require dewatering, applicant shall be required to carry out regular monitoring of dewatering discharge rate (using a digital water flow meter) and submit the data through the web portal to HWRA as applicable. Monitoring records and results should be retained by the applicant for two years, for inspection or reporting as required by HWRA.
6. Installation of Sewage Treatment Plants (STP) shall be mandatory for new projects, where ground water requirement is more than 50 m³/day. The water from STP shall be utilized for toilet flushing, car washing, gardening etc.
7. For infrastructure dewatering/ construction activity, NOC shall be valid for specific period as per the detailed proposal submitted by the applicant or for one year, whichever is earlier.
8. All residential apartments or group housing societies requiring water for drinking/domestic use only, shall pay groundwater abstraction charges on quarterly basis as per Table 5.1.
9. All infrastructure projects drawing ground water in safe, semi-critical and critical assessment units shall be required to pay ground water abstraction charges on quarterly basis as applicable as per Table 5.3 A.
10. All infrastructure projects (new/ existing) drawing ground water in over-exploited assessment units shall be liable to pay ground water restoration charges on quarterly basis as per Table 5.3 B.
11. All the tube wells/ground water abstraction structures permitted shall be fixed with digital electromagnetic/ultrasonic water meters, by the applicant at its own cost with telemetry system and monthly ground water abstraction data shall be recorded in a logbook. Compliance to this condition shall be reported within one month from the date of issue of this letter. Daily water meter readings to be recorded in a dedicated register and shall be submitted on the web portal to HWRA on quarterly basis or through centralized mechanism evolved by HWRA.
12. The applicant, as per approved proposal, shall implement rainwater harvesting and ground water recharge measures within three months from the date of issuance of this NOC and undertake periodic maintenance of recharge structures. Photographs (with geo tag only) of the recharge structures etc. and compliance of completion of construction of the same along with copy of NOC shall be furnished immediately to the Haryana Water Resources Authority for verification, on the Email ID of the Authority (compliance - hwra@hry.gov.in)
13. The ground water chemical quality shall be monitored twice in a year during pre & post- monsoon period.
14. The monthly ground water level monitoring data in respect of piezometer shall be submitted quarterly to the Haryana Water Resources Authority on regular basis.
15. In case of renewal, application shall be submitted online within 90 days before the expiry of this NOC and abstraction of ground water, after expiry of NOC shall be illegal and liable for legal action as per law.
16. The applicant shall seek prior permissions from HWRA for any increase in daily quantum of groundwater abstraction (i.e. more than the permitted limit in the NOC)..
17. Where the applicant granted NOC for abstraction of saline water and the existing well(s) is/are yielding fresh water, the same shall be sealed and new tube well(s) tapping saline water shall be constructed within 3 months of the issuance of NOC or from the date of seal of the fresh water tube well, as the case may be. The applicant shall be also ensuring safe disposal of saline residue, if any.
18. The applicant shall ensure the 100% reuse for non potable usage of self generated waste water after due treatment. He shall also ensure to reuse for non potable usage the Treated Waste Water (other than self generated) as per application and NOC terms & conditions.
19. The applicant shall comply with the provisions of the Haryana Water Resources (Conservation, Regulation and Management) Authority Act, 2020, Rules, regulations, guidelines and directions issued thereunder. Non-compliance of these provisions shall be liable for the penalty as per the provisions of the Act, rules and regulations, guidelines and directions issued thereunder.
20. Since, this NOC has been issued on the basis of self-assessment by the applicant and without any site inspection, hence the Authority may inspect the site/unit and documents at any time. In case any material difference is found in the information submitted and the site conditions or documents, the Authority may suspend the NOC granted immediately and may revoke or modify the NOC after giving a notice to the applicant.
21. This NOC is subject to prevailing State Government rules/law of Courts orders related to construction of tube well, ground water withdrawal, construction of recharge or conservation structure/discharge of effluents or any such matters as applicable.
22. The applicant shall comply with the directions/conditions/instructions issued by any Court of law related to the matters concerned with the Authority.
23. The applicant shall report self-compliance duly signed by authorized person along with authorization letter by e-mail to Haryana Water Resources Authority quarterly as well as yearly basis after the issuance of NOC.
24. This NOC does not absolve the applicant of his obligation/requirement to obtain the necessary approvals from the statutory and administrative Authorities/Departments.
25. The issuance of this NOC does not imply that other statutory or administrative clearances shall necessarily be granted to the applicant by the concerned authorities. The concerned Authorities shall act as per their own procedure.
26. The applicant shall immediately inform the HWRA, if any change in the information provided by the applicant in the application form for seeking NOC.
27. This NOC shall not absolve the applicant from any penalty/punishment/environment compensation, which may have been imposed or may be imposed, for abstraction of groundwater during such period, before the issuance of this NOC.
28. In case of non-payment or delayed payment of ground water abstraction/restoration charges, a penal interest @ 18% p.a. shall be charged.
29. The necessary compliance shall be submitted to the Authority on the web portal of the Authority i.e. www.hwra.org.in or on the email id compliance-hwra@hry.gov.in.
30. Applicant to comply IS:10500:2012 standards before use of abstracted ground water for drinking & domestic purposes.
- 31.